

HENAN GONDOR INDUSTRY CO., LTD.

 **Tel:** +8617324804737

 **E-mail:** inquiry@gondorindustry.com

 **Website:** www.gondorindustry.com



GONDOR
INNOVATION MAKES VALUES



www.gondorindustry.com



糖果生产企业设备解决方案



目录 CONTENTS

公司简介

/ P01-02

生产设备

BSF	硬糖伺服浇注生产线 SERVO DRIVEN HARD CANDY DEPOSITING PLANT	03	BCBT	工艺棒棒糖自动浇注生产线 TOY LOLLIPOP PLANT	15
BSFR	真空熬糖软糖伺服浇注生产线 VACUUM COOKER AND SOFT CANDY SERVO DRIVEN DEPOSITING PLANT	05	BLGA	连续真空转子熬糖机 CONTINUOUSLY VACUUM MICROFILM COOKING	17
BSFD-II	多功能伺服浇注生产线 MULTI-FUNCTION SERVO DEPOSITING PLANT	07	BSRT	凝胶软糖浇注成型机 JELLY CANDY DEPOSITING LINE	19
BLJC	连续真空薄膜熬糖自动浇注成型生产线 DEPOSITED HARD CANDY PRODUCTION LINE	09	BRTF	软糖辅助设备 SOFT CANDY AUXILIARY EQUIPMENT	21
BTFT	太妃糖自动浇注成型生产线 TOFFEE CANDY DEPOSITING PLANT	11	BCM 300	硬糖夹心冲压成型生产线 HARD CANDY FORMED MACHINE	23
BSFB	球形棒棒糖自动插棒伺服浇注生产线 SERVO BALL LOLLIPOP PLANT	13			

熬煮设备

BZBA-X	全自动连续真空薄膜熬糖机 FULLY AUTOMATIC MICROFILM COOKER	25	BDZA	真空薄膜低温转子熬糖机 MICROFILM ROTARY COOKER	33
BZAZ	转子转锅真空熬糖机 ROTATING PAN VACUUM ROTARY COOKER	27	BJCA	连续真空软糖熬糖机 JELLY CANDY VACUUM COOKER	35
BLGA-500	连续真空转子熬糖机 CONTINUOUSLY VACUUM MICROFILM COOKER	29	BJH	焦化熬糖机 CARBLEND COOKER	37
BZBA	连续真空薄膜熬糖机 MICROFILM COOKER	31	BPCA-300	太妃批次熬糖锅 TOFFEE BATCH COOKER	39

辅助设备

BAFD	称重, 混合喂料系统 WEIGHING, MIXING AND FEEDING PLANT	41	BLBC	糖果实验熬煮机 COOKER FOR CANDY LABORATORY	47
BLCD	糖果实验浇注机 CANDY CASTING MACHINE	43		转子泵 ROTOR PUMP	48
BLB	拉白机 WHITE PULLING EQUIPMENT	45		糖果模具 CANDY MOULD	49



BSF

SERVO DRIVEN HARD CANDY DEPOSITING PLANT

硬糖伺服浇注生产线



技术规格 SPECIFICATION

生产能力 Production capacity	300-800kg (按每粒5克计算As per 5g candy)
耗电量 Power consumption	30-45kw
压缩空气耗量 Compressed air consumption	0.5m³/min
压缩空气压力 Air pressure	P=0.4-0.6MPa
蒸汽耗量 Steam consumption	450kg/h
蒸汽压力 Pressure of steam	P<0.7MPa
用水量 Water consumption	2200L/h
外形尺寸 Size	13m(长)x2m(宽)x2.7m(高)
整机重量 Weight of machine	6000kg

性能及特点 PURPOSE AND CHARACTERISTIC

BSF系列真空薄膜熬糖硬糖伺服浇注生产线是目前先进的糖果浇注生产设备，它采用全伺服控制于一体，结构紧凑，具有较高的自动化程度。该机产量高，生产效率显著，不仅能生产单色水晶糖，夹心糖，也能生产双色双味糖，斑纹糖及司考奇等。

The BSF series microfilm cooker and servo driven hard candy depositing plant are the advanced equipment for candy depositing, they are driven by servo motors and controlled by intelligent card, with tight construction and high automation and also with large outputs. They can produce transparent candy, center-filled candy, twin color& twin flavor candy, stripe candy and butter scotch, etc.

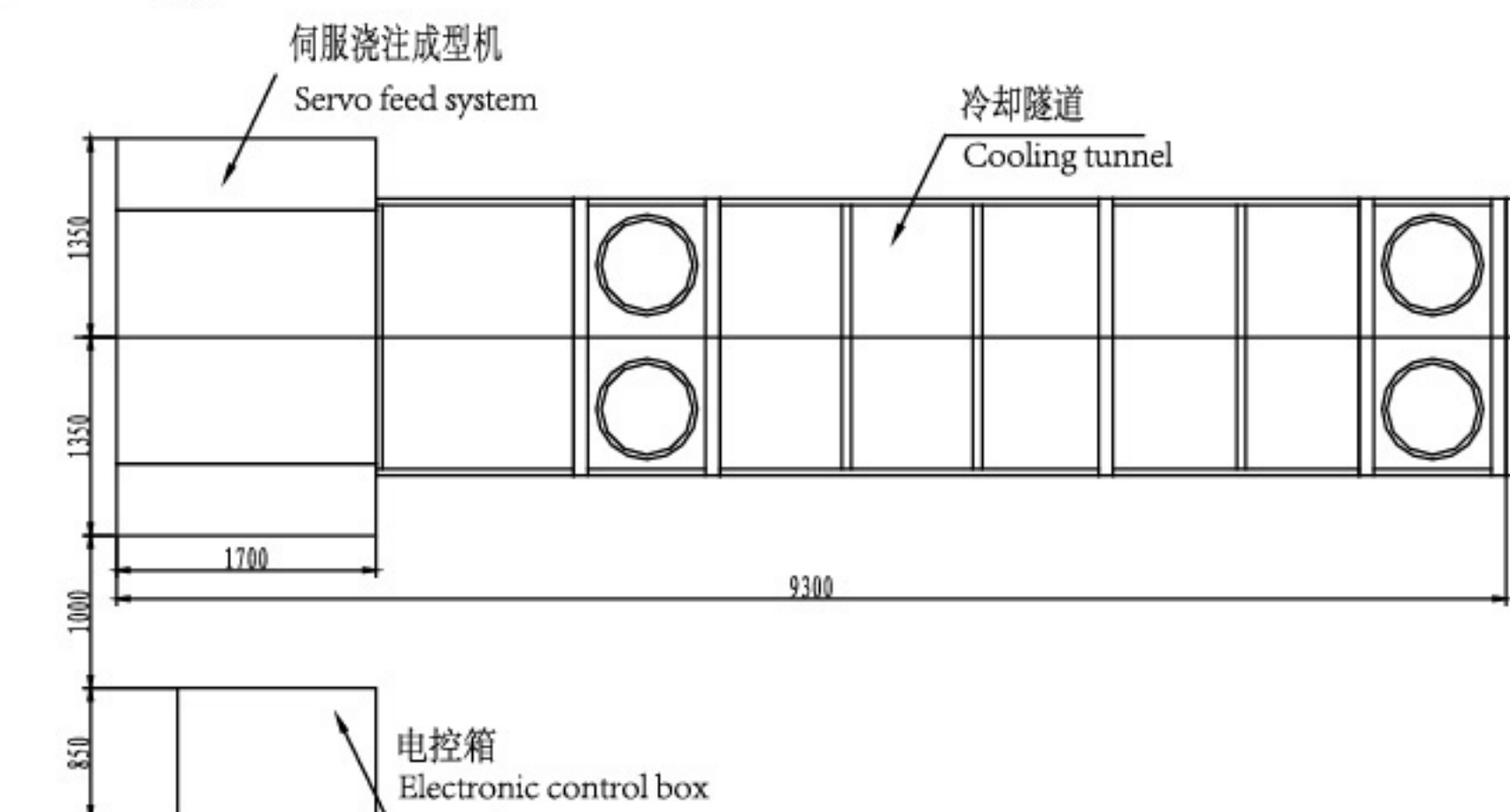



BSFR

VACUUM COOKER AND SOFT CANDY SERVO DRIVEN DEPOSITING PLANT
真空熬糖软糖伺服浇注生产线



www.gondorindustry.com

性能及特点 PURPOSE AND CHARACTERISTIC

BSFR系列真空熬糖软糖浇注生产线是目前先进的软糖硬模浇注设备，它集机、电、气于一体，也可以采用全伺服控制，结构紧凑，具有较高的自动化程度。是生产卡拉胶、明胶立体和半立体软糖的理想设备。

The BSFR series Vacuum cooker and soft candy depositing plant are the advanced equipment for soft candy with alu. moulds. They combined by mechanical, electric and pneumatic, and can be controlled by servo driven also. With tight construction and high automation, they are the best choose for produce carrageenan, gelatin solid and half solid candy

技术规格 SPECIFICATION

生产能力 Production capacity	150-600kg (按每粒5克计算As per 5g candy)
耗电量 Power consumption	15-30kw
压缩空气耗量 Compressed air consumption	0.5m³/min
压缩空气压力 Air pressure	P=0.4-0.6MPa
蒸汽耗量 Steam consumption	450kg/h
蒸汽压力 Pressure of steam	P<0.7MPa
用水量 Water consumption	2000L/h
外形尺寸 Size	18m(长)x2m(宽)x2.7m(高)
整机重量 Weight of machine	5000kg

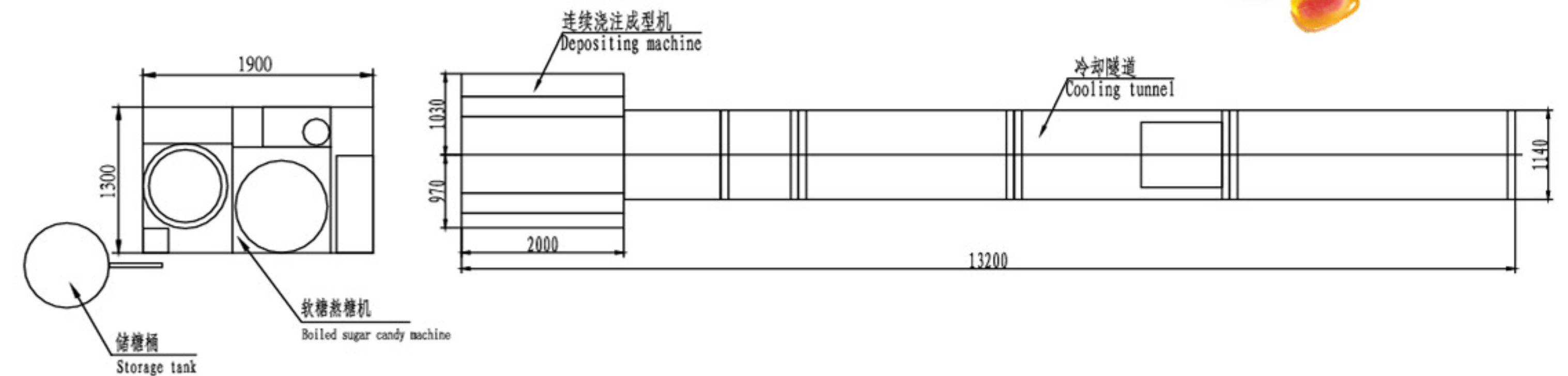



BSFD-II MULTI-FUNCTION SERVO DEPOSITING PLANT 多功能伺服浇注生产线



性能及特点 PURPOSE AND CHARACTERISTIC

BSFP-II 多功能连续伺服浇注线是目前我公司走在国内同行业前端的全自动糖果生产成型设备, 该设备可浇注成型单色糖、杏仁奶脆糖及话梅扁棒等糖果。控制器使用进口的独立式系统级多轴运动控制器。每个运动轴都配置为伺服轴用以驱动伺服电机做精确定位和定速控制。设备运行快速、精确而且平稳, 且使用操作简单, 大大提高工作效率。

BSFP-II The multi-function servo depositing plant is advanced and fully automatic candy production line for single color candy cream candy with nut, flat lollipop with plum and so on. All the motion is controlled by the servo motor which makes exact depositing position and steady running speed. Also, this plant is easy to operate, with high efficiency and high output.

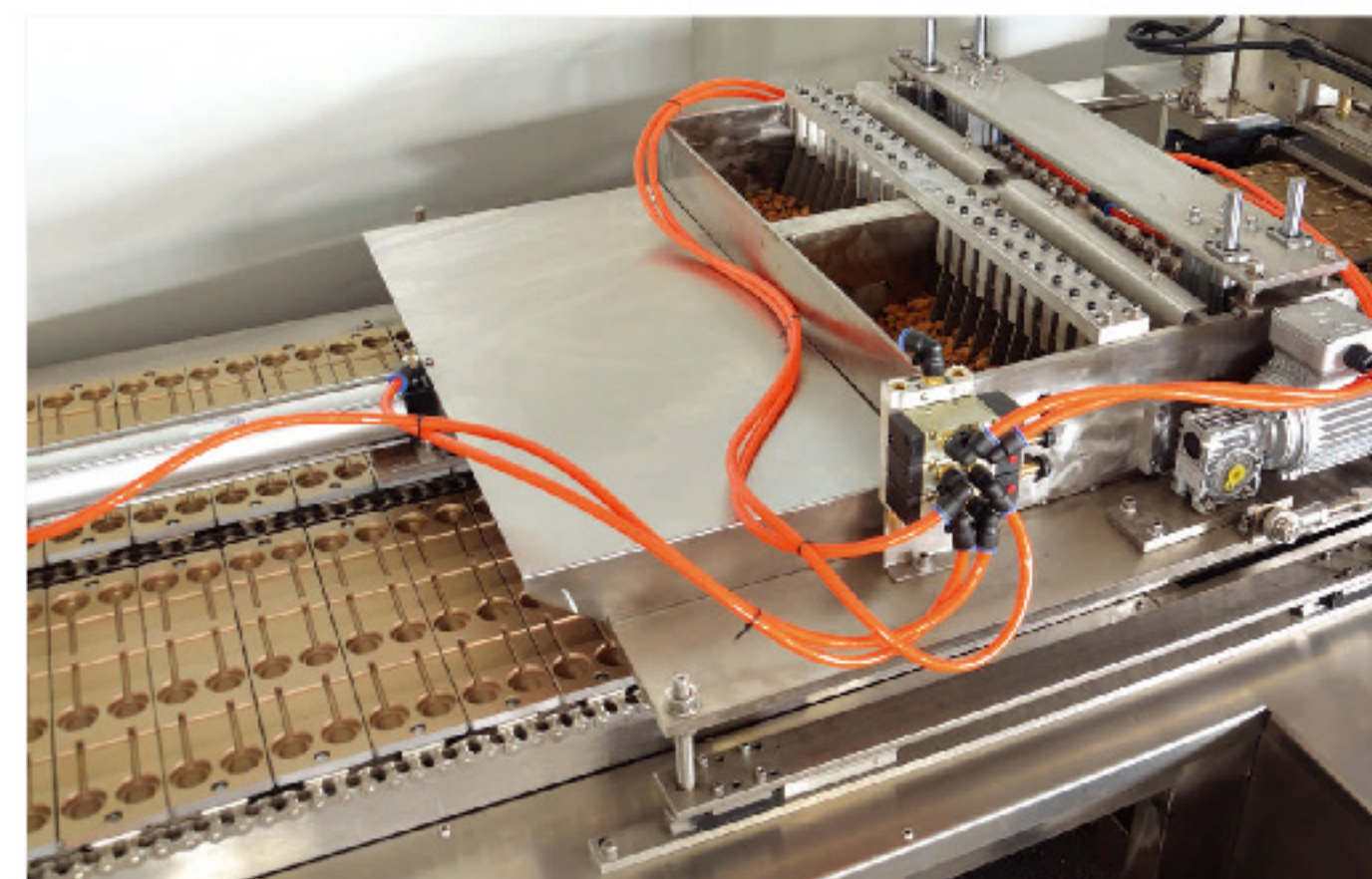

技术规格 SPECIFICATION

生产能力 Production capacity	15000 pcs/h
耗电量 Power consumption	25kw
压缩空气耗量 Compressed air consumption	1m³/min
压缩空气压力 Air pressure	P= 0.4-0.8MPa
蒸汽耗量 Steam consumption	450kg/h
蒸汽压力 Pressure of steam	P<0.8MPa
用水量 Water consumption	2200L/h
外形尺寸 Size	12.5m(长)x 2m(宽)x 2.6m(高)
整机重量 Weight of machine	6000kg

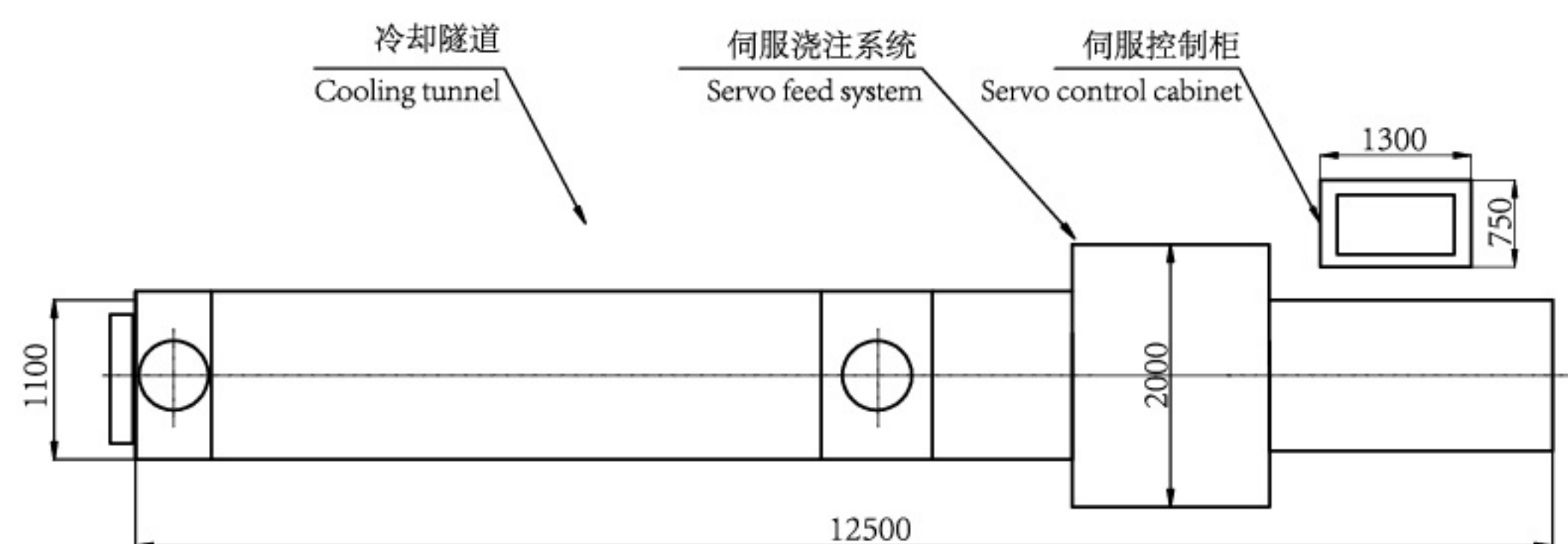
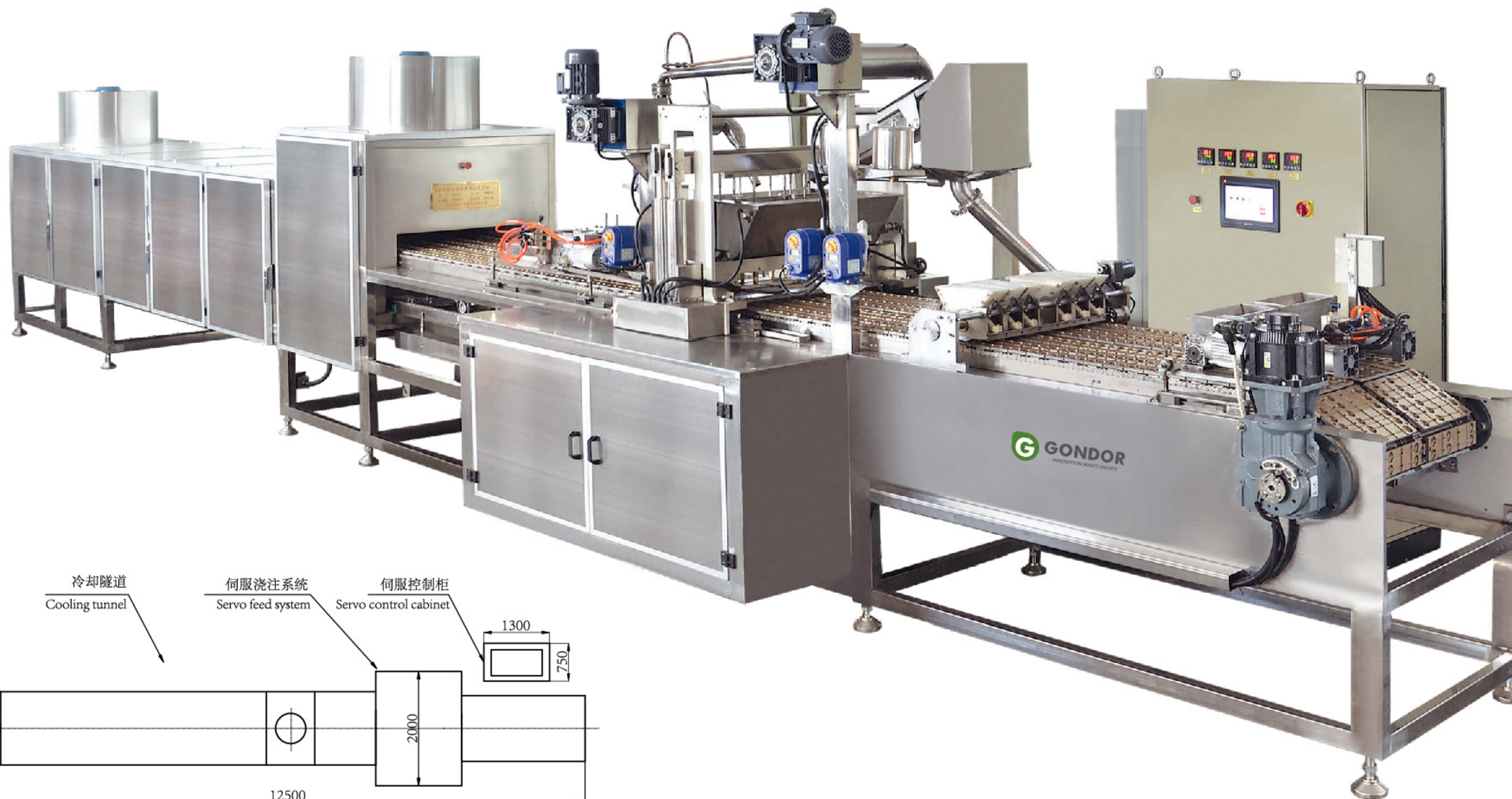



BLJC

DEPOSITED HARD CANDY PRODUCTION LINE
连续真空薄膜熬糖自动浇注成型生产线



性能及特点 PURPOSE AND CHARACTERISTIC

BLJC系列真空薄膜熬糖连续自动浇成型生产线是目前先进的糖果生产设备，它集机、电、气于一体，结构紧凑，具有较高的自动化程度。该机产量高，生产效率显著，不仅能生产单色水晶糖，夹心糖，也能生产双色双味糖，斑纹糖及司考奇等。

BLJC series vacuum microfilm cooking continuous pour shaping auto-producing line is the advanced confectionery machine at the present time, it gathers machine and electric all in one. This machine have the features of compact structure and highly automatic. With high output and good production efficiency. It can produce not only crystal candy, center-fill candy but also twin colors & twin flavor candy, stripe candy and coffee candy. The produced candy which made from this machine have transparent and smooth surface and good taste.



技术规格 SPECIFICATION

生产能力 Production capacity	300-800kg (按每粒5克计算As per 5g candy)
耗电量 Power consumption	30-45kw
压缩空气耗量 Compressed air consumption	0.5m ³ /min
压缩空气压力 Air pressure	P=0.4-0.6MPa
蒸汽耗量 Steam consumption	450kg/h
蒸汽压力 Pressure of steam	P<0.7MPa
用水量 Water consumption	2200L/h
外形尺寸 Size	13m(长)x2m(宽)x2.7m(高)
整机重量 Weight of machine	6000kg





BTFT TOFFEE CANDY DEPOSITING PLANT 太妃糖自动浇注成型生产线



技术规格 SPECIFICATION

生产能力 Production capacity	150-450kg (按每粒6克计算As per 6g candy)
耗电量 Power consumption	20-40kw
压缩空气耗量 Compressed air consumption	0.5m³/min
压缩空气压力 Air pressure	P=0.4-0.6MPa
蒸汽耗量 Steam consumption	300kg/h
蒸汽压力 Pressure of steam	P<0.6MPa
用水量 Water consumption	1500L/h
外形尺寸 Size	16m(长)x2m(宽)x2.3m(高)
整机重量 Weight of machine	6000kg

性能及特点 PURPOSE AND CHARACTERISTIC

BTFT太妃糖真空刮锅式熬糖连续自动浇注成型生产线是目前最先进的太妃糖浇注生产设备。它集机、电、气于一体，采用弹性硅胶模具，气动式自动脱模，具有较高的自动化程度，该机产量高，生产效率显著，不仅能生产单色纯太妃糖、双色太妃糖、夹心太妃糖，也能生产喷花带夹心太妃糖等。

BTFT toffee candy depositing plant is the most developed equipment for producing the toffee candy. It gathers machine and electric all in one, using the silicon moulds, and demoulding automaticly by pneumatic system, with highly automatic. This plant with high output, suit for producing pure toffee, double color toffee, centre filling toffee and stripe toffee with centre filling and so on.

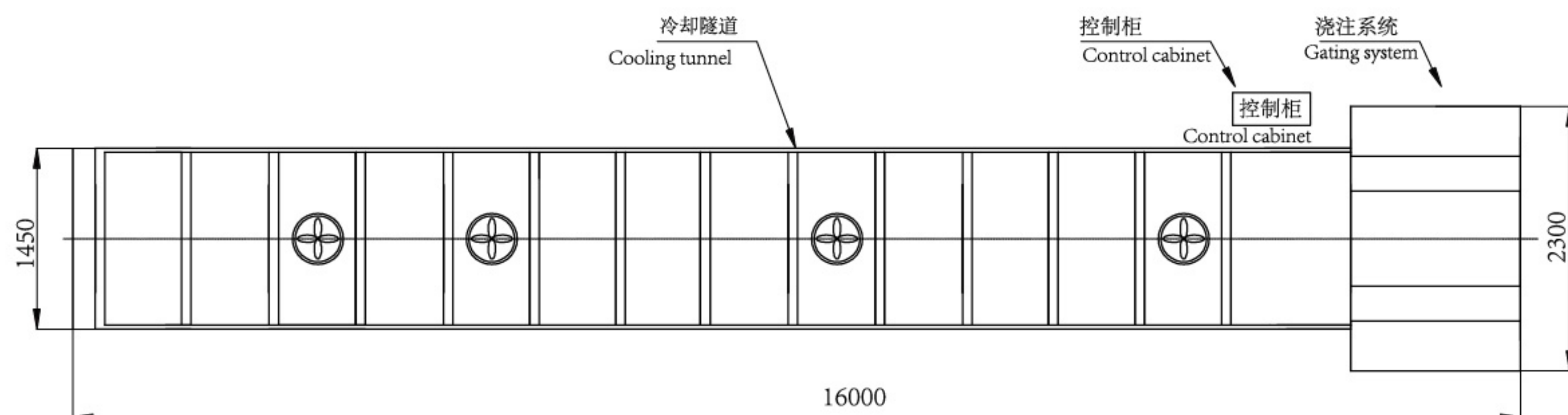



BSFB SERVO BALL LOLLIPOP PLANT

球形棒棒糖自动插棒伺服浇注生产线



技术规格 SPECIFICATION

生产能力 Production capacity	36000 pcs/h
生产速度 Production speed	30-40/min
耗电量 Power consumption	45kw
压缩空气耗量 Compressed air consumption	0.3m³/min
压缩空气压力 Air pressure	P=0.6-0.8MPa
使用环境温度 Ambient temperature	20-25 °C
使用环境湿度 Operating humidity	55%
外形尺寸 Size	13m(长)x3.7m(宽)x2.6m(高)
整机重量 Weight of machine	7000kg

性能及特点 PURPOSE AND CHARACTERISTIC

BSFB 球形棒棒糖伺服浇注线是目前我公司走在国内同行业前端的全自动伺服浇注和自动化伺服插棒的糖果生产成型设备。该设备可浇注成型单色棒棒糖、双色棒棒糖等多种色系糖果。控制器使用进口的独立式系统级多轴运动控制器。每个运动轴都配置为伺服轴用以驱动伺服电机做精确定位和定速控制。设备运行快速、精确而且平稳，且使用操作简单，替代以往人工插棒等诸多人工费用，大大提高工作效率为企业节省成本。

BSFB The servo ball lollipop plant is advanced and fully automatic production line with servo deposit and servo stick insertion, no need manual stick insertion. It is suitable for production of single color lollipop, double color lollipop or other multi color lollipop. The controller is the imported multi-axis motion controller with independent system. All the motion is controlled by the servo motor which makes exact depositing, position and steady running speed. Also, this plant is easy to operate, with high efficiency and high output.

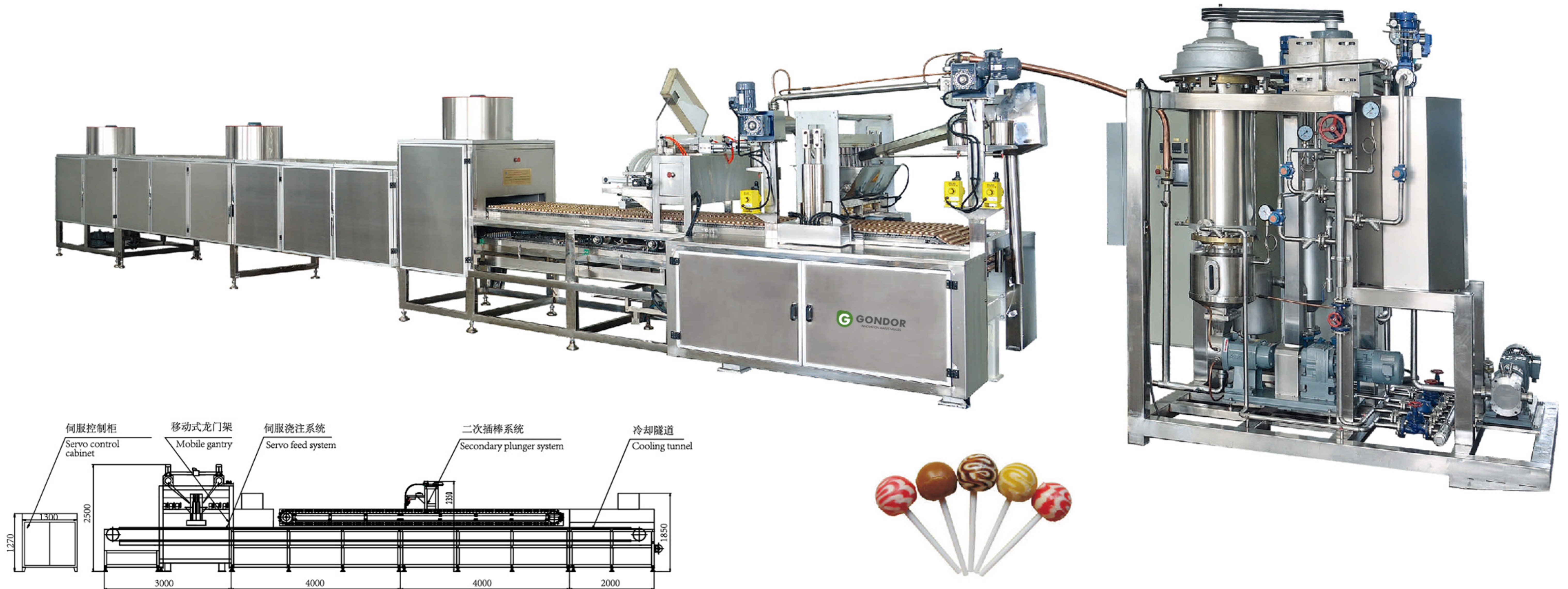
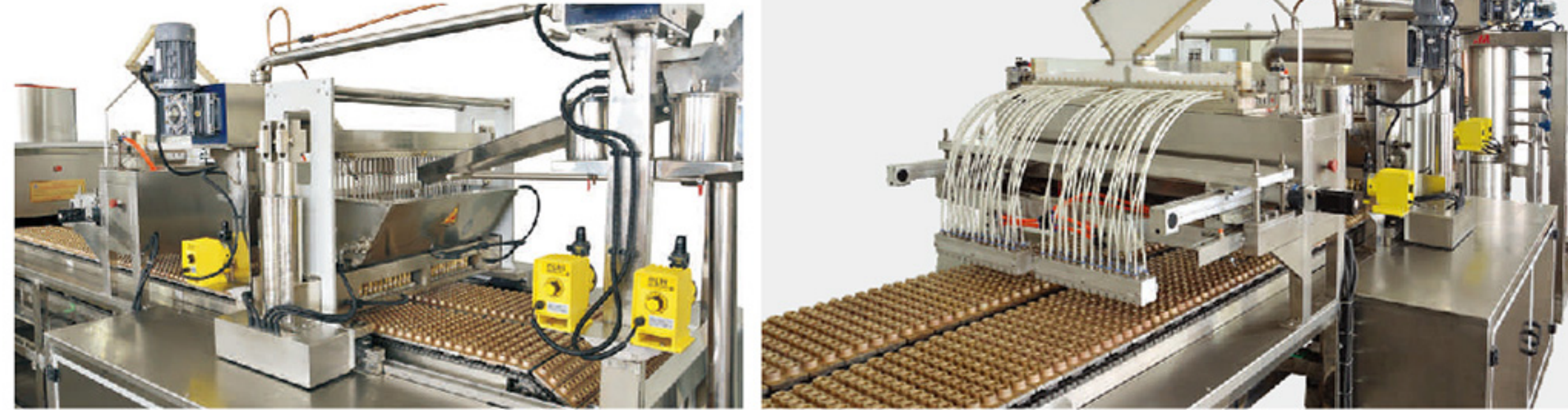



BCBT TOY LOLLIPOP PLANT 工艺棒糖自动浇注生产线

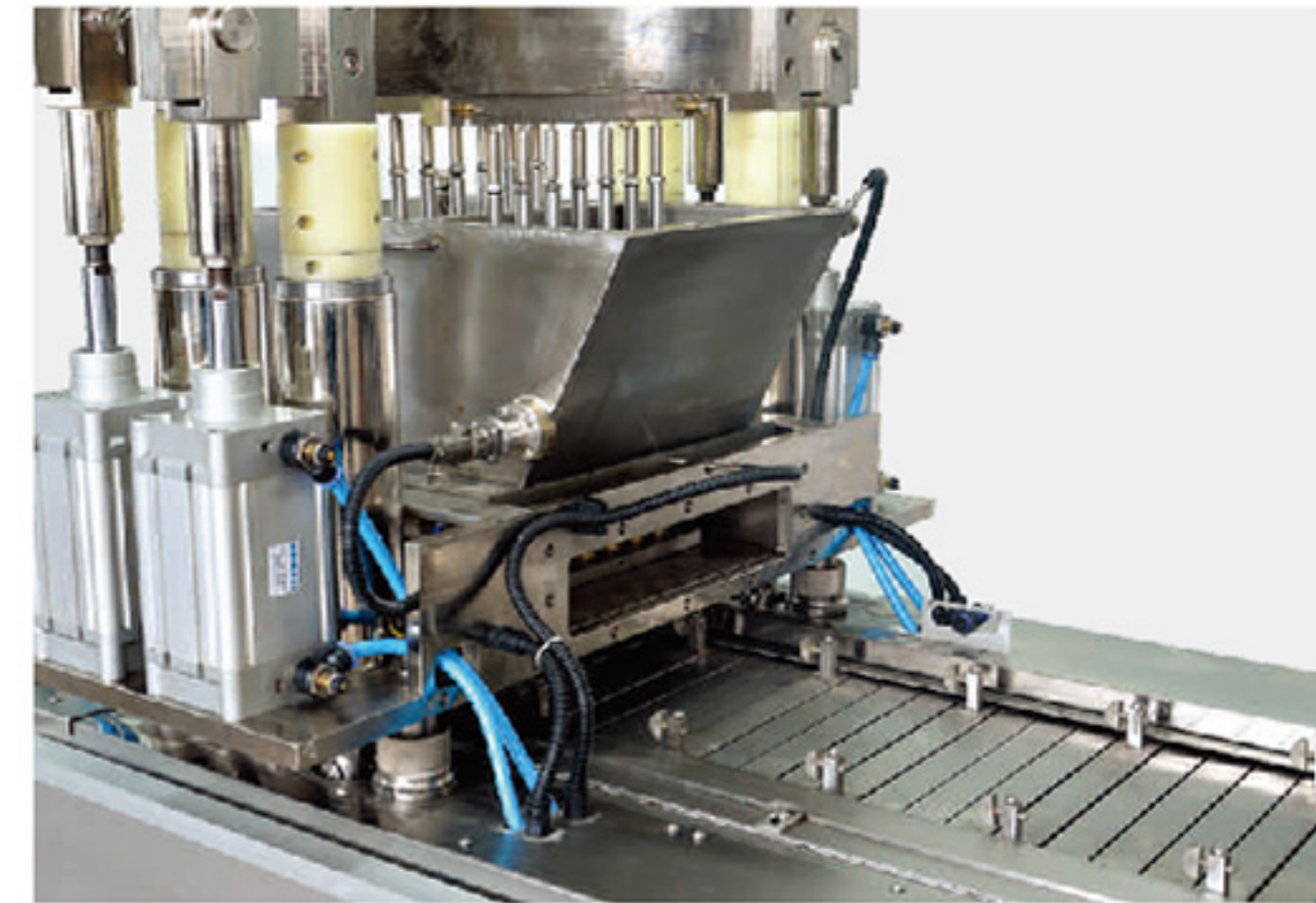

技术规格 SPECIFICATION

生产能力 Production capacity	120-750kg/h
糖粒重量 Weight of candy	5-40g/粒 grain
糖型 Candy shape	根据客户要求 According customers require
耗电量 Power consumption	12kw
耗气量 Air consumption	120m ³ /h
用水量 Water consumption	2200L/h
蒸汽耗量 Steam consumption	450kg/h
蒸汽压力 Pressure of steam	P<0.7MPa
机器占地面积 Area for the machine	21x0.9x2.6m
整机重量 Weight of machine	6000kg

性能及特点 PURPOSE AND CHARACTERISTIC

BCBT棒糖自动浇注生产线是一种工艺型的棒糖生产设备，它适合于大颗粒糖型，不仅能生产半立体、全立体的造型棒糖，还能生产手工模棒糖。能生产单色、上下、左右双色双味棒糖、喷花棒糖。该机集机、电、气于一体，取消凸轮结构，结构紧凑，设计合理，具有较高的自动化程度，是理想的棒糖生产设备。

BCBT deposited lollipop production line is one kind of art candy production equipment which suit for the large grain of candy shape. This machine not only producing semi-solid and full solid lollipop but also producing normal lollipop. Can producing single color, double color double flavour lollipop, stripe lollipop. This machine with mechanic, electric, pneumatic and cancel the cam system, construction tightly, designing reasonable with high automatically, it is a perfect lollipop production equipment.

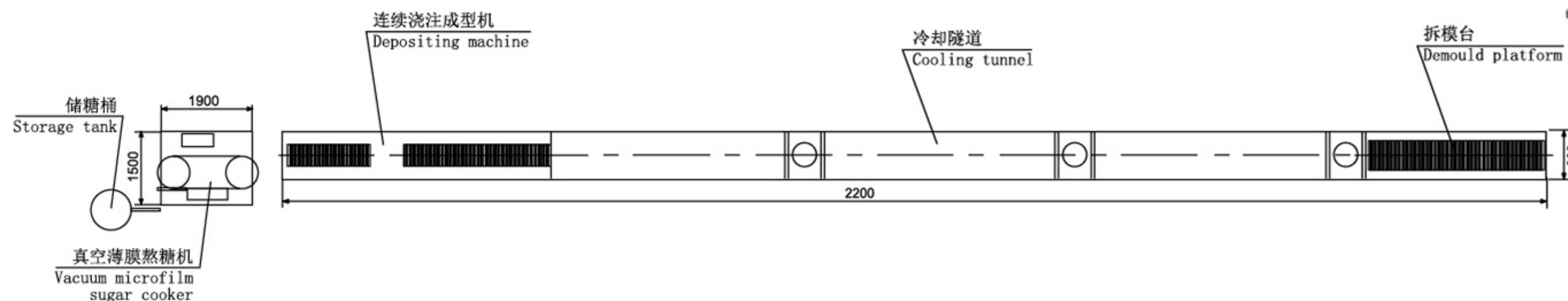
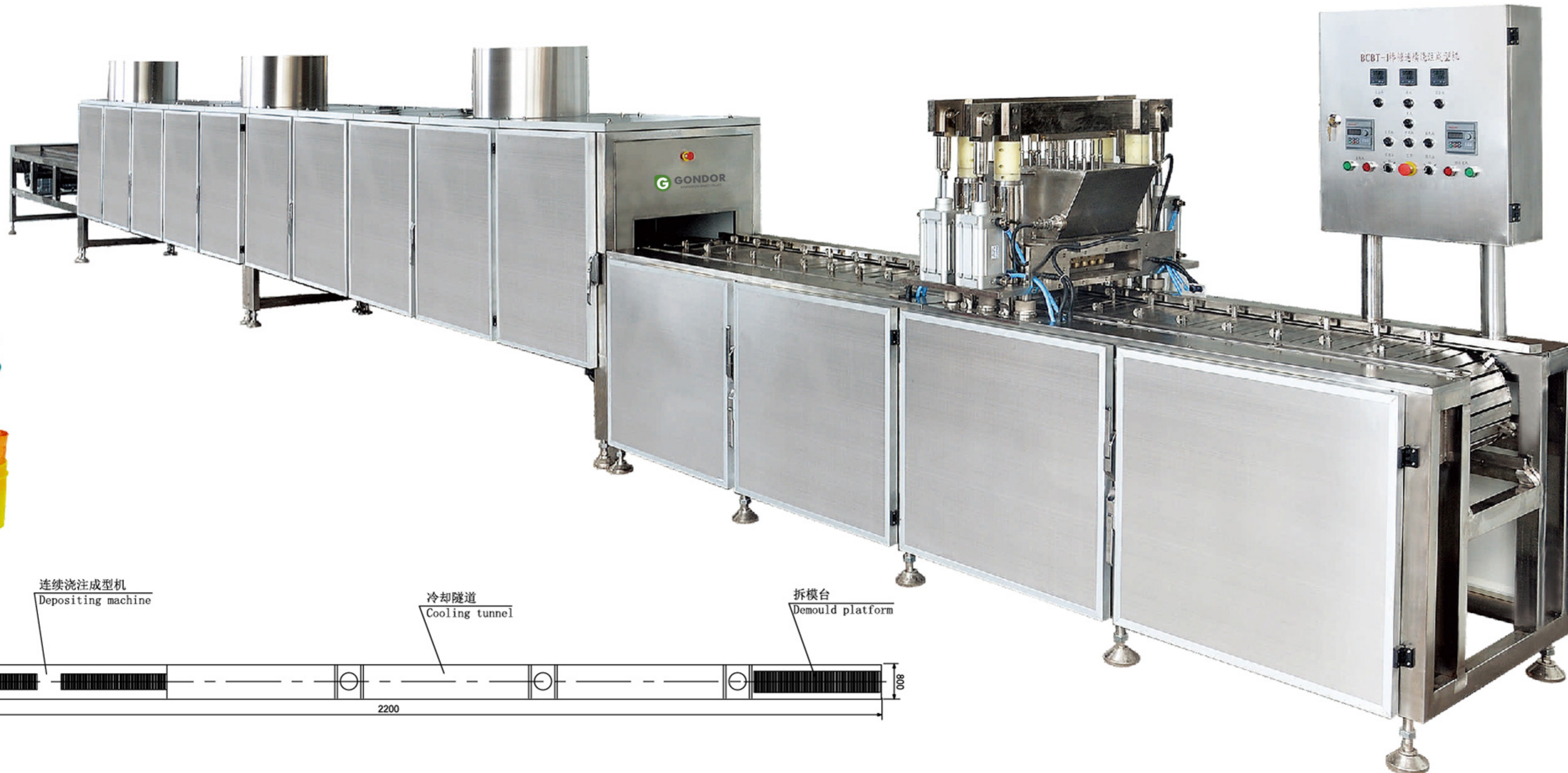



BLGA MILK CANDY ROTARY COOKER WITH CHAIN FORMING LINE 转子熬糖奶糖链式成型生产线



性能及特点 PURPOSE AND CHARACTERISTIC

BLGA转子熬糖奶糖链式成型生产线是目前先进的连续奶糖生产线。它集转子熬煮、钢带冷却、连续拉白、冲压成型等设备。

BLGA milk candy rotary cooker with chain forming line press forming is the advanced milk candy production line, it includes microfilm cooker, steel belt cooling conveyor, continuous white pulling machine, press former and so on.

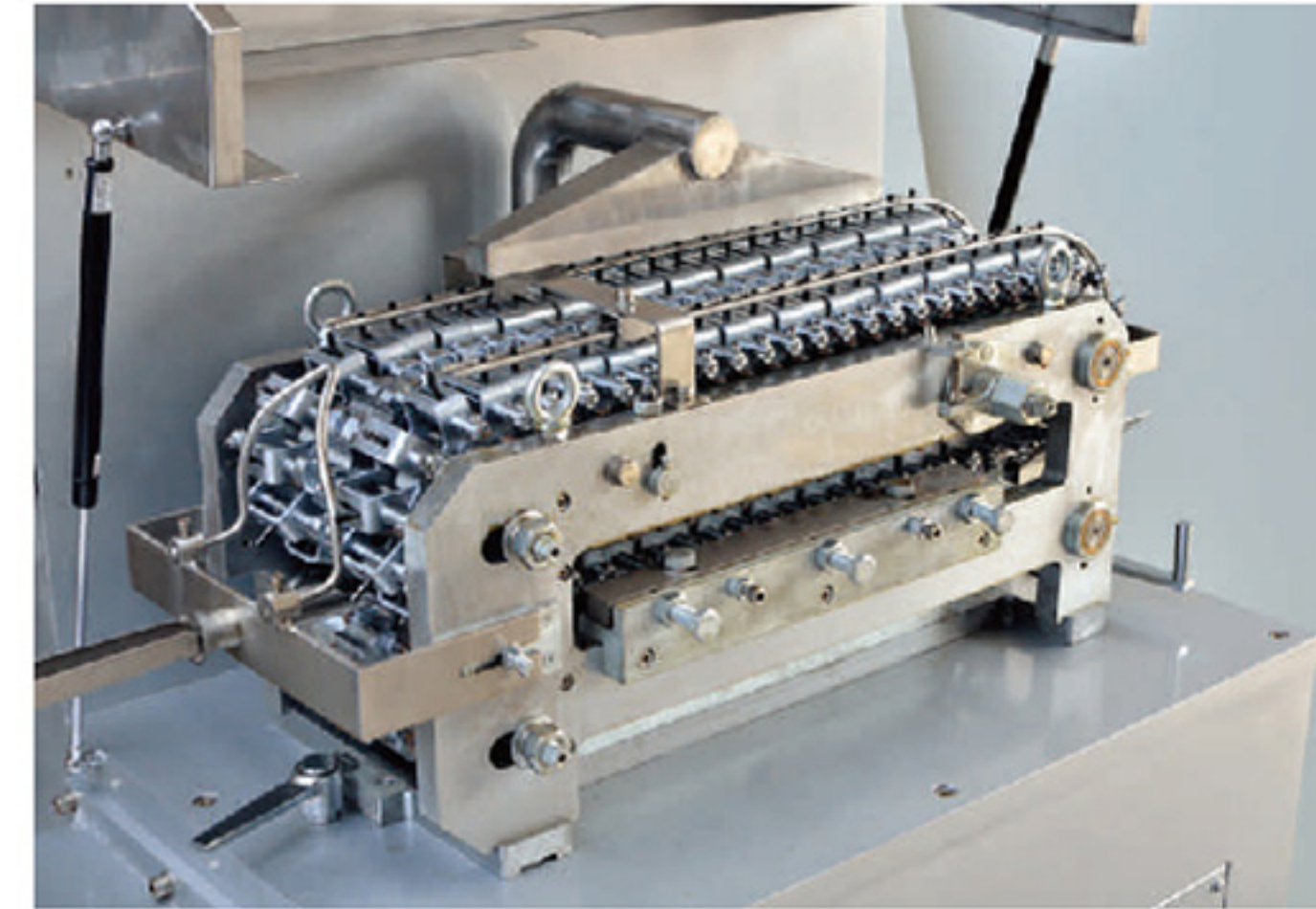
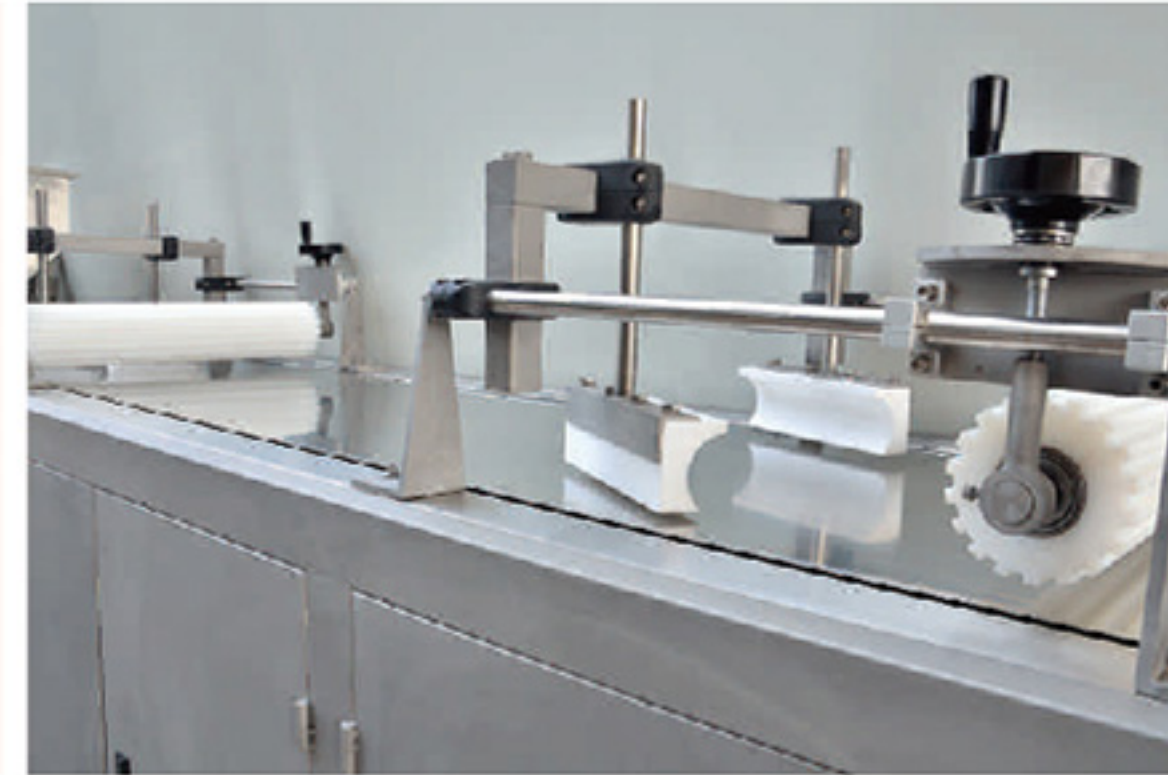

技术规格 SPECIFICATION

生产能力 Production capacity	500kg/h
糖粒重量 Weight of candy	3-5g
糖型 Candy shape	根据客户要求
耗电量 Power consumption	40kw
耗气量 Air consumption	-
用水量 Water consumption	2200L/h
蒸汽耗量 Steam consumption	500kg/h
蒸汽压力 Pressure of steam	0.6-0.8mpa
机器占地面积 Area for the machine	-
整机重量 Weight of machine	-

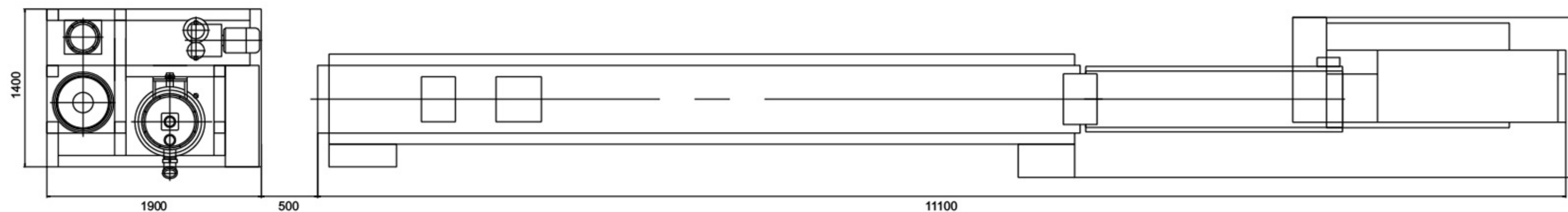



BSRT JELLY CANDY DEPOSITING LINE 凝胶软糖浇注成型机



技术规格 SPECIFICATION

生产能力 Production capacity	400kg/h
糖粒重量 Weight of candy	10g
糖型 Candy shape	-
耗电量 Power consumption	15kw
耗气量 Air consumption	0.9mpa
用水量 Water consumption	-
蒸汽耗量 Steam consumption	-
蒸汽压力 Pressure of steam	-
机器占地面积 Area for the machine	13mX1.2mX1.8m
整机重量 Weight of machine	3000kg

性能及特点 PURPOSE AND CHARACTERISTIC

BSRT凝胶软糖浇注成型机是通用型软糖浇注设备。它集伺服电机、气动于一体。可生产单色、双色软糖，是生产卡拉胶、果胶、软糖的理想设备。

BSRT jelly candy depositing line is the universal soft candy production line. It integrates servo motor and pneumatic system, can produce single color, double color, center filling candy, this is the desired production line for pectin, carrageenan and so on.

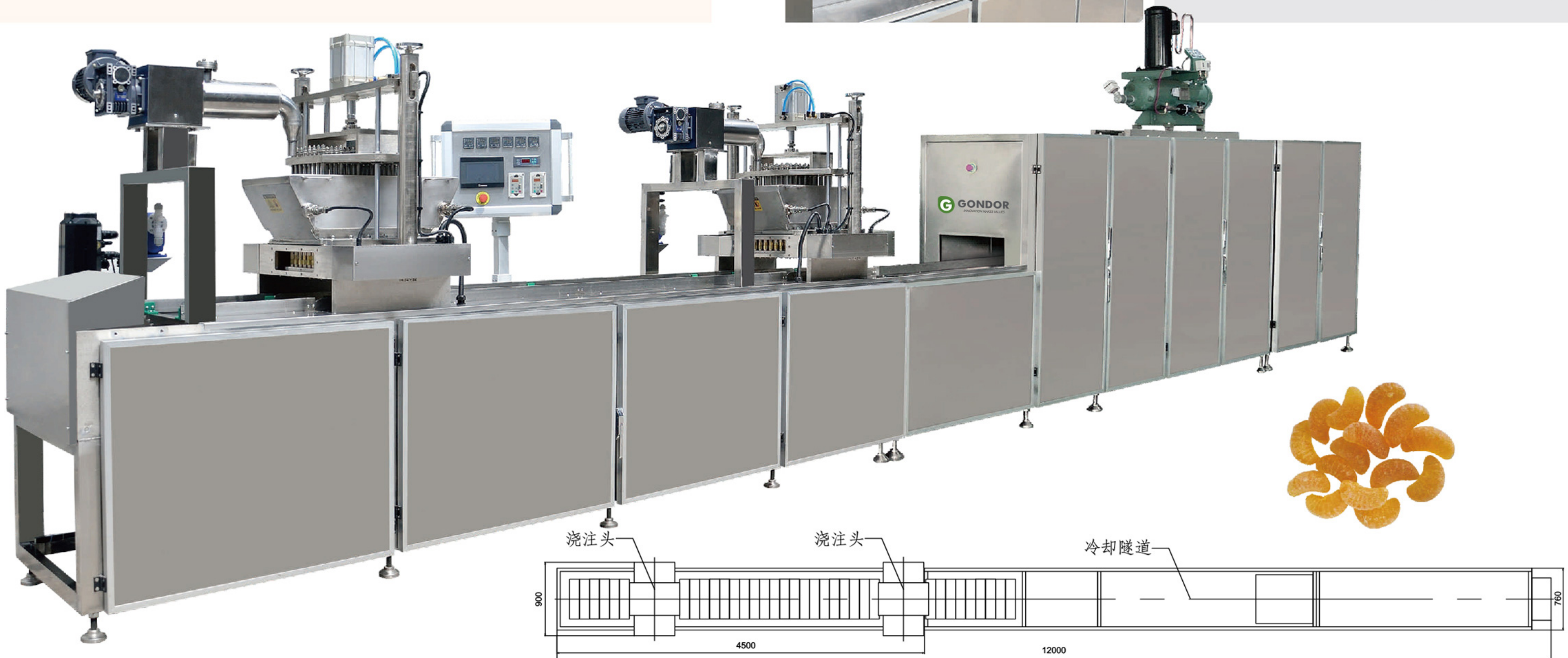



BRTF SOFT CANDY AUXILIARY EQUIPMENT

软糖辅助设备



性能及特点 PURPOSE AND CHARACTERISTIC

BRTF软糖辅助设备包括预撒糖机、涂糖（油）机、爬坡机和七层除湿冷柜。该设备适合果胶软糖等免烘烤的软糖。

BRTF soft candy auxiliary equipment include sugar pre-coating,sugar and oil coating machine, climbing conveyyor,multilayer cooling tunnel,this equipment is apply to soft candy which is not need roast.

技术规格 SPECIFICATION

生产能力 Production capacity	400-1000kg/h
糖粒重量 Weight of candy	-
糖型 Candy shape	-
耗电量 Power consumption	20kw
耗气量 Air consumption	-
用水量 Water consumption	-
蒸汽耗量 Steam consumption	350kg
蒸汽压力 Pressure of steam	0.3mpa
机器占地面积 Area for the machine	20mX4mX2.2m
整机重量 Weight of machine	7000kg





BCM 300 HARD CANDY FORMED MACHINE 硬糖夹心冲压成型生产线



性能及特点 PURPOSE AND CHARACTERISTIC

BCM 300 硬糖夹心冲压成型生产线是一种高性能的糖果冲压设备。它由夹心泵、保温辊床、均条机、冲压成型机、冷却隧道组成。该机集机、电、气于一体可同步自动控制夹心、拉条、成型，结构紧凑，设计合理，具有较高的自动化程度，是理想的冲压成型设备。

BCM 300 hard candy die forming production line is a high-powered candy die-forming equipment. It consists of the centre filling machine, rope sizer, liner, former, cooling tunnel. These machine combined by machine, electricity and air, can controlling centre filling, lining, former, structure tightly, designing reasonable, with high automaticly, it is ideal candy forming equipment.

技术规格 SPECIFICATION

生产能力 Production capacity	250-400kg/h
冲压速度 Forming speed	1000pcs/min
最大糖重 Tax candy weight	7g
冷却要求 (温度、湿度) Tooling requirement (temperature, humidity)	20-25°C 55%
耗电量 Power consumption	12kw
外形尺寸 Size	10m(长)x1.2m(宽)x1.6m(高)
整机重量 Weight of machine	3500kg





BZBA-X FULLY AUTOMATIC MICROFILM COOKER

全自动连续真空薄膜熬糖机



技术规格 SPECIFICATION



生产能力 Production capacity	300-500kg(按每粒5克计算) AS PER 5G CANDY
耗电量 Power consumption	16kw
压缩空气耗量 Compressed air consumption	0.3m³/min
压缩空气压力 Air pressure	P=0.4-0.6MPa
蒸汽耗量 Steam consumption	450kg/h
蒸汽压力 Pressure of steam	P<0.7MPa
用水量 Water consumption	2200L/h
外形尺寸 Size	2.3m x2m x2.7m
整机重量 Weight of machine	2500kg

性能及特点 PURPOSE AND CHARACTERISTIC

BZBA-X全自动连续真空熬糖机具有全自动控制糖液温度及流量的功能，该机具有产量高、熬糖质量好、糖浆透明度高、操作简便的特点。该机与BLJC自动浇注成型机或BCBT棒糖自动浇注生产线配套使用，是理想的真空熬糖设备。

BZBA-X fully automatic microfilm cooker is installed with automatic control system for syrup temperature and the flow of syrup. The cooker is easy to operate, with high output. And the cooked syrup is high quality and high grade of transparency. It is perfect to use this cooker together with BLJC fully automatic candy depositing plant or BCBT fully automatic lollipop depositing plant.

布局图 LAYOUT

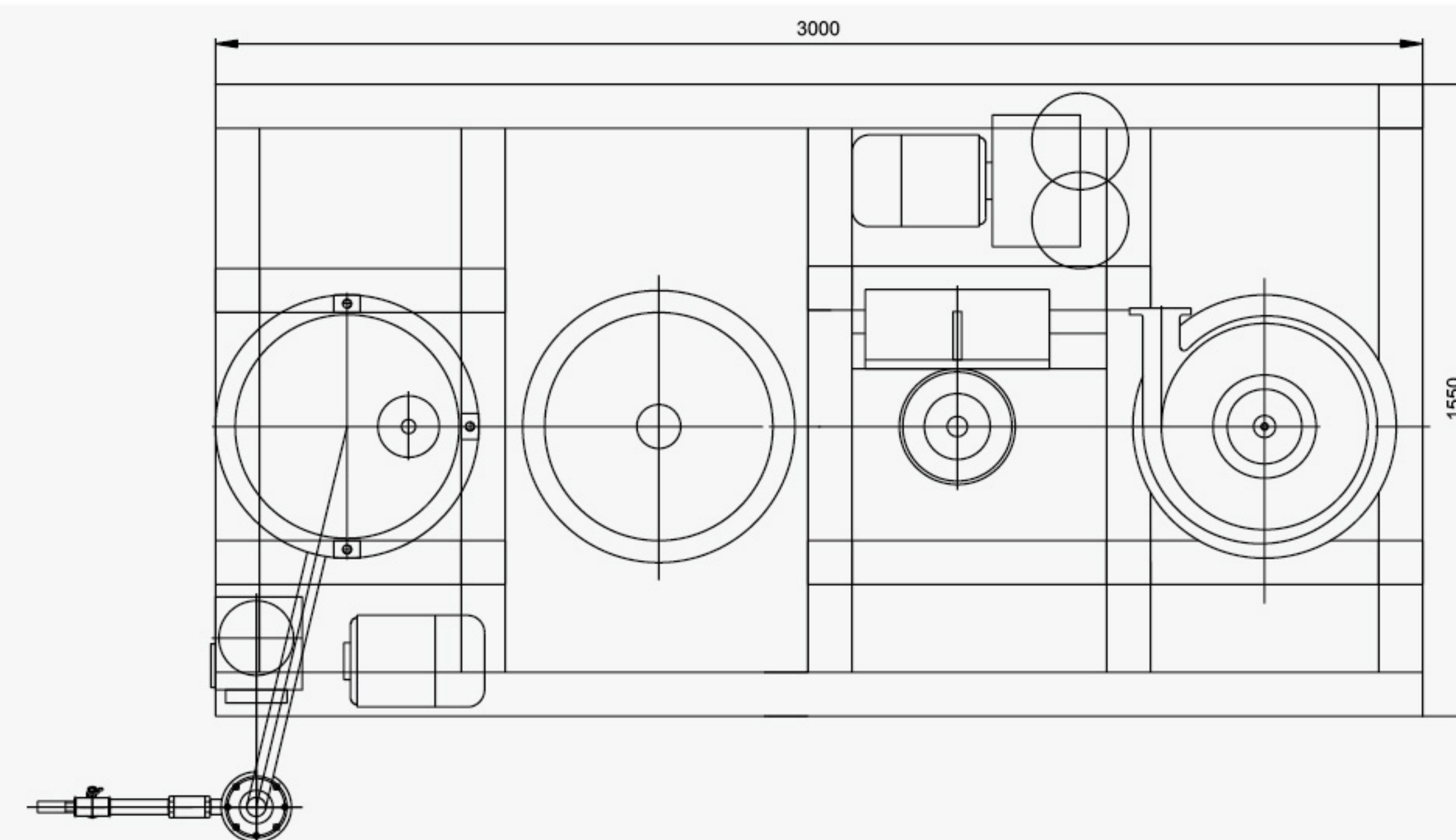



BZAZ

ROTATING PAN VACUUM ROTARY COOKER
转子转锅真空熬糖机



技术规格 SPECIFICATION

生产能力	400-600kg/h
耗电量	10kw
压缩空气耗量	0.3m³/min
压缩空气压力	P=0.4-0.6MPa
蒸汽耗量	450kg/h
蒸汽压力	P<0.7MPa
用水量	2200L/h
外形尺寸	2.3m(长)x1.6m(宽)x2.3m(高)
整机重量	2000kg

Production capacity	400-600kg/h
Power consumption	10kw
Compressed air consumption	0.3m³/min
Air pressure	P=0.4-0.6MPa
Steam consumption	450kg/h
Pressure of steam	P<0.7MPa
Water consumption	2200L/h
Size	2.3m(L)x1.6m(W)x2.3m(H)
Weight of machine	2000kg

性能及特点 PURPOSE AND CHARACTERISTIC

BZAZ转子转锅真空熬糖机，是目前高效的低温转子熬糖设备。操作方便，结构合理。工作性能稳定可靠，与硬糖冲压线等其他成型设备配合使用。

BZAZ rotating pan vacuum rotary cooker is the advanced low temperature sugar cooking equipment, it has easy operation, reasonable structure, stable work, can be used with hard candy and soft candy press former.



布局图 LAYOUT

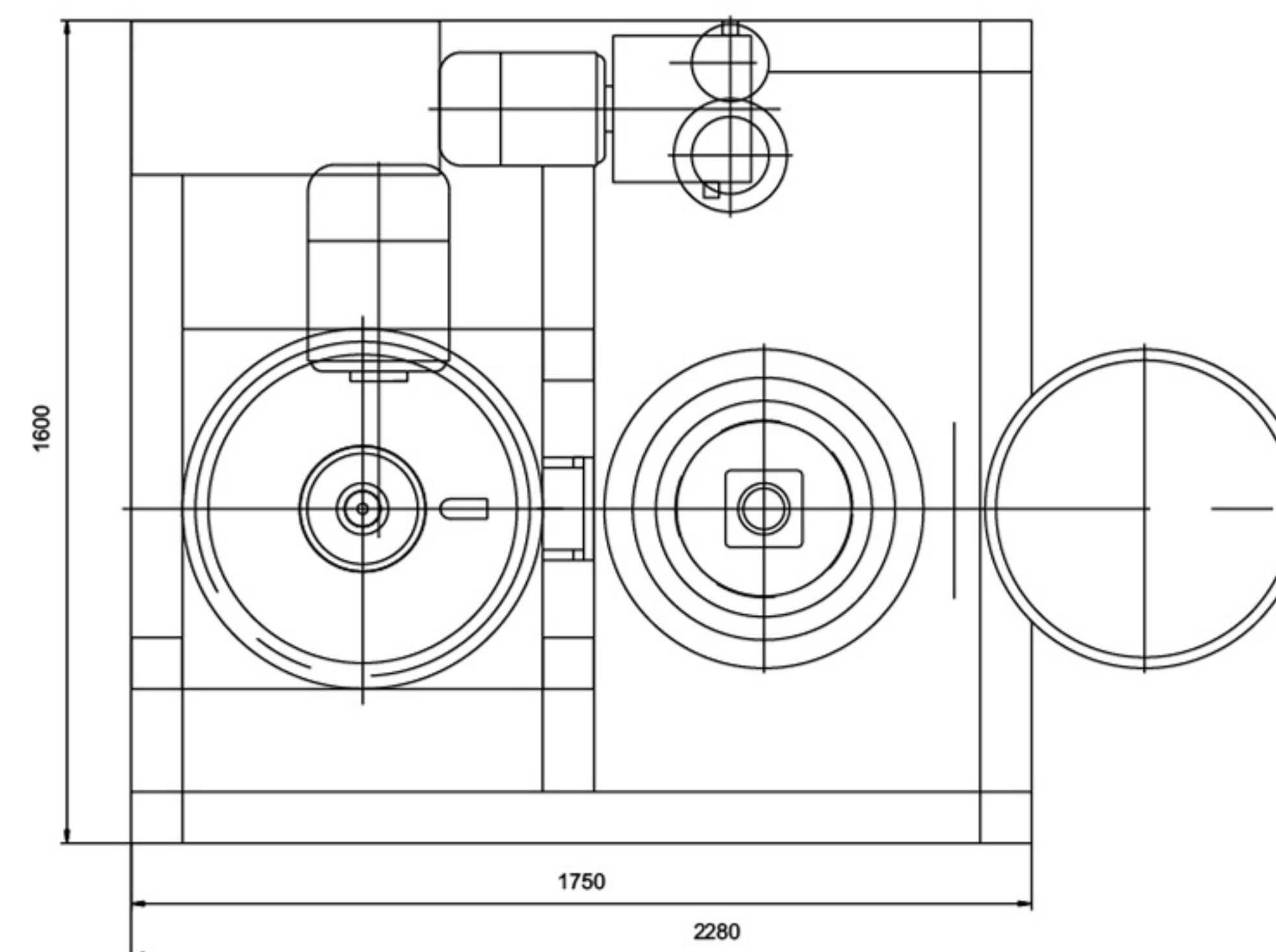



BLGA-500 CONTINUOUSLY VACUUM MICROFILM COOKER 连续真空转子熬糖机



技术规格 SPECIFICATION

生产能力	500kg
耗电量	20kw
压缩空气耗量	0.3m³/min
压缩空气压力	P=0.4-0.6MPa
蒸汽耗量	450kg/h
蒸汽压力	P<0.7MPa
用水量	2200L/h
外形尺寸	2m(长)x1.5m(宽)x2.3m(高)
整机重量	2500kg

Production capacity	500kg
Power consumption	20kw
Compressed air consumption	0.3m³/min
Air pressure	P=0.4-0.6MPa
Steam consumption	450kg/h
Pressure of steam	P<0.7MPa
Water consumption	2200L/h
Size	2m (L)x1.5m(W)x2.3m(H)
Weight of machine	2500kg

性能及特点 PURPOSE AND CHARACTERISTIC

BLGA-500连续真空转子熬糖机是先进的通用性糖浆连续真空高速熬煮设备。适用于熬煮硬糖、奶糖、硬太妃糖。该机熬煮的糖浆透明度高，气泡少，色泽均匀。

BLGA-500 continuously vacuum microfilm cooker is the advanced sugar cooking equipment, It apply to hard candy, milk candy, hard toffee candy and so on. The syrup after cooking has high transparency, uniform color and less bubble

布局图 LAYOUT

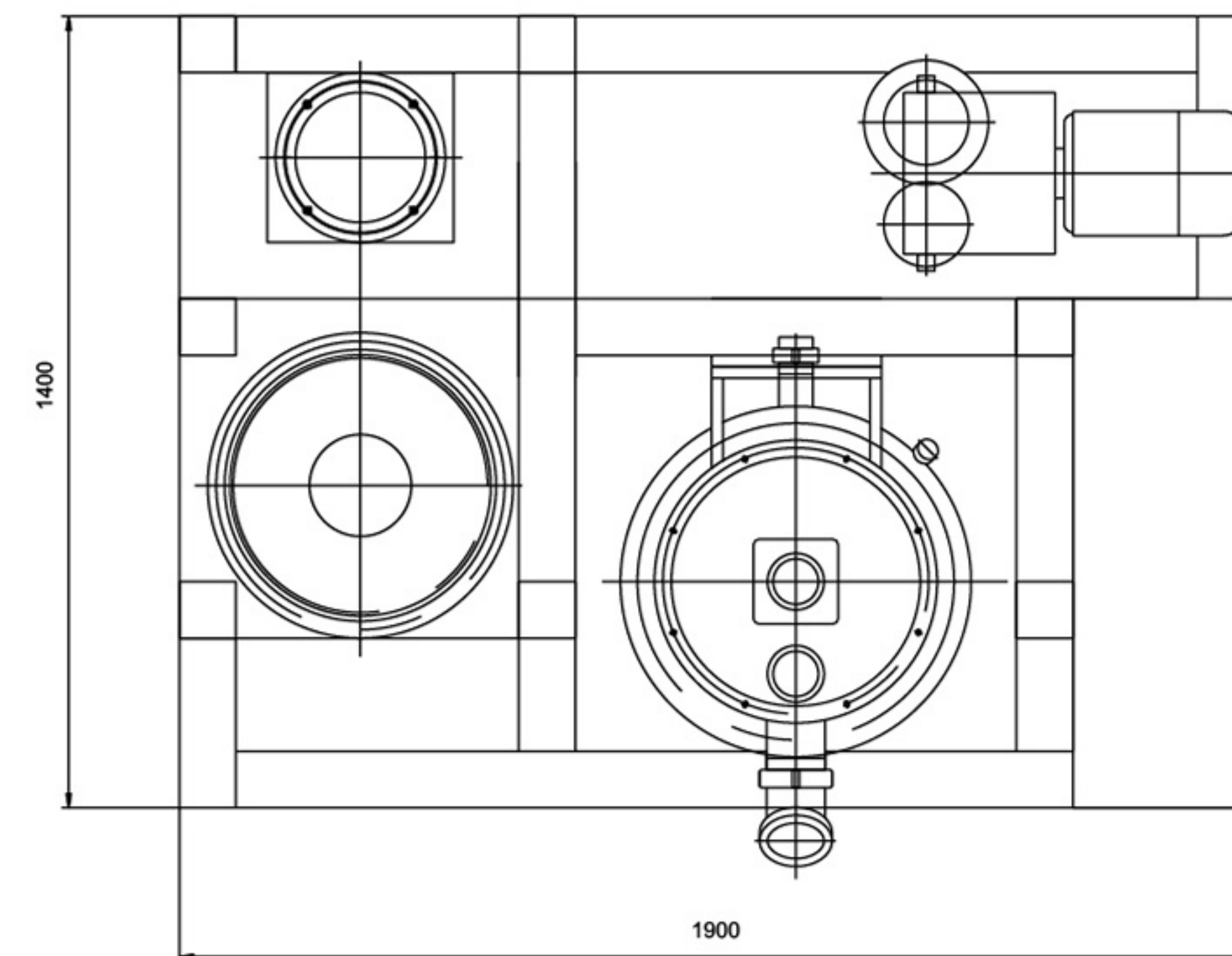



BZBA MICROFILM COOKER 连续真空薄膜熬糖机



技术规格 SPECIFICATION

生产能力	300-500kg(按每粒5克计算)
耗电量	16kw
压缩空气耗量	0.3m³/min
压缩空气压力	P=0.4-0.6MPa
蒸汽耗量	450kg/h
蒸汽压力	P<0.7MPa
用水量	2200L/h
外形尺寸	2.3m(长)x2m(宽)x2.7m(高)
整机重量	2500kg

Production capacity	300-500KG (AS PER 5G CANDY)
Power consumption	16kw
Compressed air consumption	0.3m³/min
Air pressure	P=0.4-0.6MPa
Steam consumption	450kg/h
Pressure of steam	P<0.7MPa
Water consumption	2200L/h
Size	2.3m(L)x2m(W)x2.7m(H)
Weight of machine	2500kg



性能及特点 PURPOSE AND CHARACTERISTIC

BZBA连续真空薄膜熬糖机具有连续自动熬糖和自动控温的功能，该机具有产量高、熬糖质量好、糖浆透明度高、操作简便的特点。该机与BLJC自动浇注成型机或BCBT棒棒糖自动浇注生产线配套使用，是理想的真空熬糖设备。

Model BZBA mikrofilm cooker has the function of auto-continuous sugar-cooking and auto-control the temperature. High output, good quality of sugar cooking, high transparency of syrup and convenient operation. It can be used together with BLJC depositing machine or BCBT lollipop production line. It is the perfect equipment of sugar-cooking.

布局图 LAYOUT

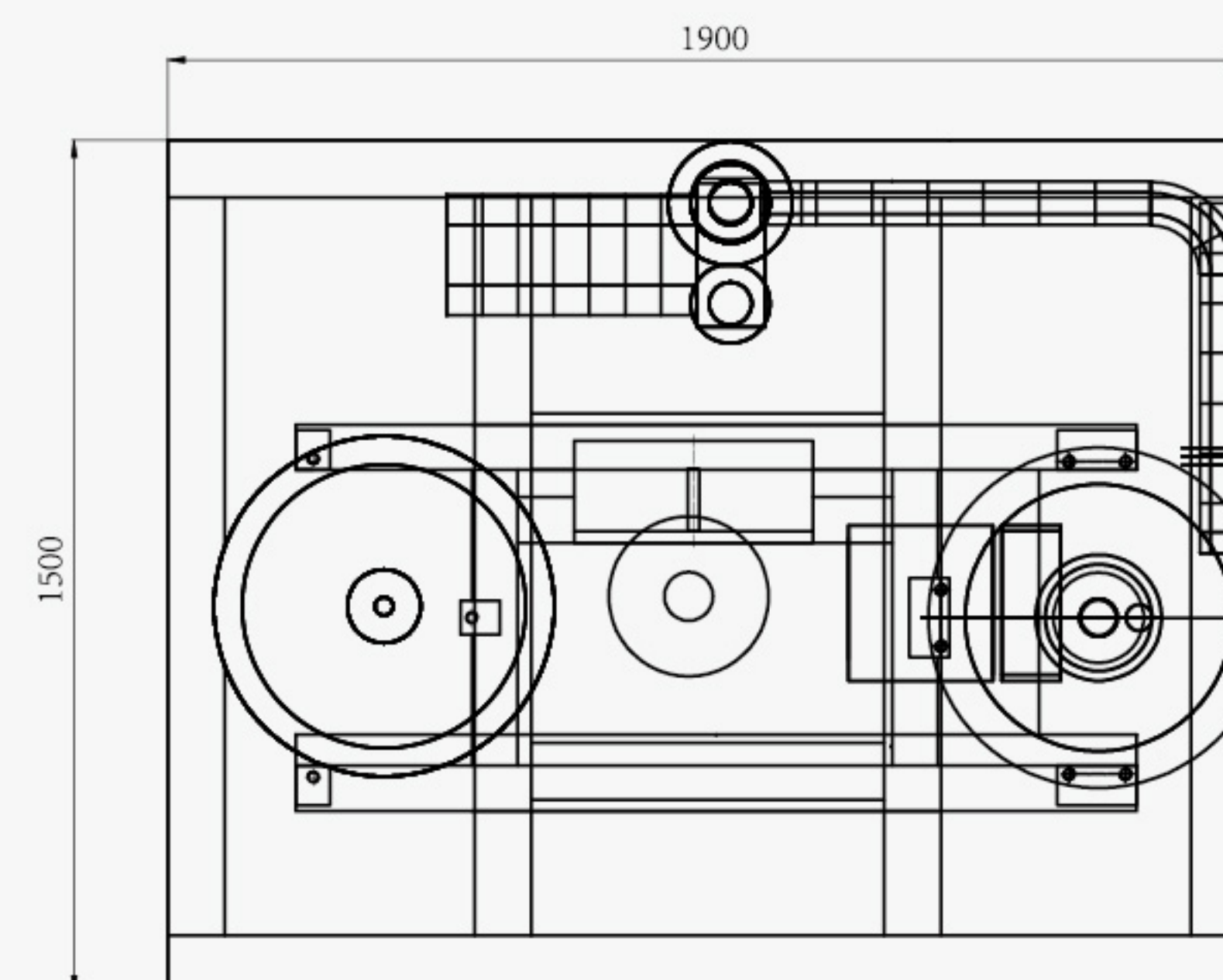



BDZA MICROFILM ROTARY COOKER 真空薄膜低温转子熬糖机



技术规格 SPECIFICATION

生产能力	300-500kg(按每粒5克计算)
耗电量	25kw
压缩空气耗量	0.3m³/min
压缩空气压力	P=0.4-0.6MPa
蒸汽耗量	400kg/h
蒸汽压力	P<0.3MPa
用水量	3000L/h
外形尺寸	3.0m(长)x1.8m(宽)x3.6m(高)
整机重量	3600kg

Production capacity	300-500KG (AS PER 5G CANDY)
Power consumption	25kw
Compressed air consumption	0.3m³/min
Air pressure	P=0.4-0.6MPa
Steam consumption	400kg/h
Pressure of steam	P<0.3MPa
Water consumption	3000L/h
Size	3.0m(L)x1.8m(W)x3.6m(H)
Weight of machine	3600kg



性能及特点 PURPOSE AND CHARACTERISTIC

BDZA 真空薄膜低温转子熬糖机具有PLC自动控制，人机触摸屏参数菜单化，该机产量高，熬糖质量好，使糖浆在薄膜真空时低温浓缩，是熬制高乳脂、高乳蛋白特浓牛奶糖、鲜果汁糖、太妃糖、求斯糖和蛋白糖的理想设备。

BDZA microfilm rotary cooker controlled by PLC and touchable screen. This machine large capacity, cooked high quality slurry, cryoconcentration during vacuuming, it is the best machine for cooking high cream and high milk contents candy, fresh fruit juice candy, toffee and so on

布局图 LAYOUT

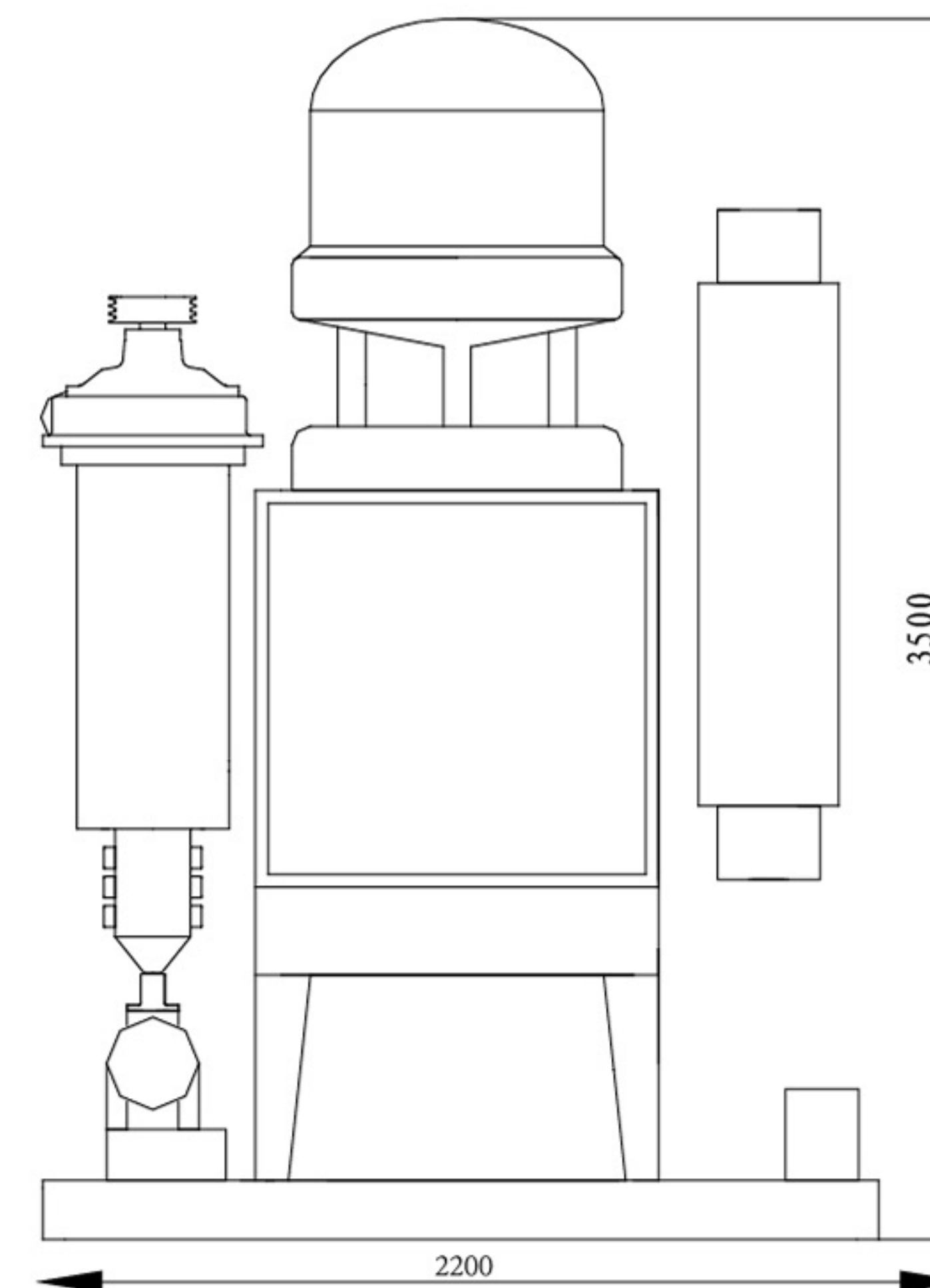



BJCA JELLY CANDY VACUUM COOKER 连续真空软糖熬糖机



技术规格 SPECIFICATION

生产能力	500-700kg(按每粒5克计算)
耗电量	15kw
压缩空气耗量	0.5m³/min
压缩空气压力	P=0.4-0.6MPa
蒸汽耗量	400kg/h
蒸汽压力	P<0.8MPa
用水量	2200L/h
外形尺寸	1.9m(长)x1.5m(宽)x2.5m(高)
整机重量	2200kg

Production capacity	500-700KG (AS PER 5G CANDY)
Power consumption	15kw
Compressed air consumption	0.5m³/min
Air pressure	P=0.4-0.6MPa
Steam consumption	400kg/h
Pressure of steam	P<0.8MPa
Water consumption	2200L/h
Size	1.9m(L)x1.5m(W)x2.5m(H)
Weight of machine	2200kg

性能及特点 PURPOSE AND CHARACTERISTIC

BJCA—连续真空软糖熬煮机是果胶，明胶，琼脂，卡拉胶以及各种变性淀粉为原材料熬制凝胶软糖的先进熬煮机。该机具有快速预热系统以及真空室来更好的控制糖的浓度，保证每一批糖浆的质量。食品接触部分采用食品级不锈钢材料制成，与浇注生产线配套使用是理想的真空熬糖设备。

BJCA jelly candy vacuum cooker is advanced and suitable for cooking of pectin, gelatin, agar, carrageenan and other modified starch for jelly production. This cooker is installed with pre-cooking system and vacuum part which control the syrup density and make high quality syrup. The material touched with food is food grade stainless steel. It is perfect to use this cooker together with depositing line.

布局图 LAYOUT

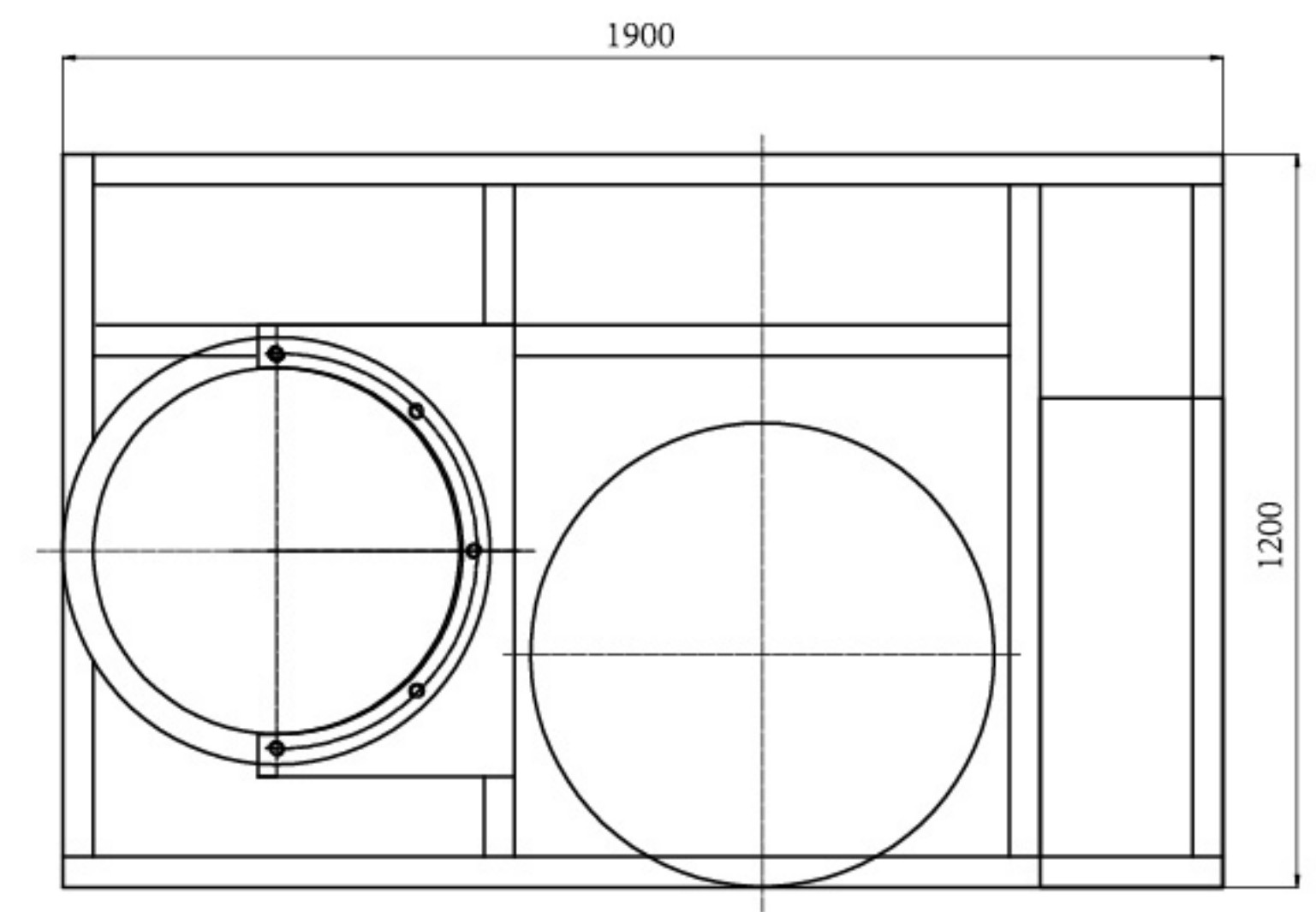



BJH CARABLEND COOKER 焦化熬糖机



技术规格 SPECIFICATION



八段熬煮器可分别调节蒸汽工作压力	
八段熬煮器搅拌转速可变频调节	
上下段出糖温度数字显示	
电压:	3 φ 380VAC+N±10% 50Hz
功率:	4.4KW
最大工作蒸汽压力:	1Mpa
外型尺寸:	4200 (L) X2000 (W) X2700 (H) mm
重量:	2500kg
产量取决于初始配方的水分含量及最终的产品, 以及所需的焦香化程度。范围在250到1100kg/hr	

Steam pressure for & sections can be adjusted separately	
Mixing speed can be adjusted steplessly	
Digital temperature display for both units	
Electrical power:	3 φ 380VAC+N±10% 50Hz
Carablend Power:	4.4KW
Max Steam Pressure:	1Mpa
Dimension:	4200 (L) X2000 (W) X2700 (H) mm
Weight:	2500kg
The output depends upon the moisture content of the initial recipe and of the final product, plus degree caramelisation required, Outputs of between 250 and 1100kg/hr can be handled.	

性能及特点 PURPOSE AND CHARACTERISTIC

BJH焦化熬糖机有两个单元, 每个单元4个蒸汽夹层区, 各区有独立的蒸汽控制、仪表等。4个区直接连在一起。在槽内旋转的是无轴不锈钢片。合成太妃糖的同时将其缓慢向前运动, 混合片造成物料的两个向前运动。向前与向反运动的组合确保了物料的充分混合。同时随着物料的混合, 叶片扫过加热表面可以防止物料焦化过度, 堵塞在表面。在单元的一端, 有一个可调节的“堰”可以调整物料的保持时间及料位。上下单元普通速调节。在卸料端有一个电子温度传感器。各桶的顶部有一个连锁护罩提起, 驱动电机就会断开。

BJH has two units in series, Each unit is made up of four steam jacketed sections or zones, Each zone has independent steam controls, gauges, etc. The four sections are connected directly together. Rotating in the trough is a shaftless steel blade. This mixes together the toffee whilst slowly moving it forward. The mixing blade results in two forward movements of the mass for every reverse movement. The combination of forward and reverse movement ensures thorough mixing. At the same time as mixing the mass the blade sweeps the heated surface of the unit preventing burning and build up at the surface. At one end of the unit there is a weir assembly which can be adjusted to vary the retention time and level of product in the unit. There is a variable speed drive driving "Carablend" units.

布局图 LAYOUT

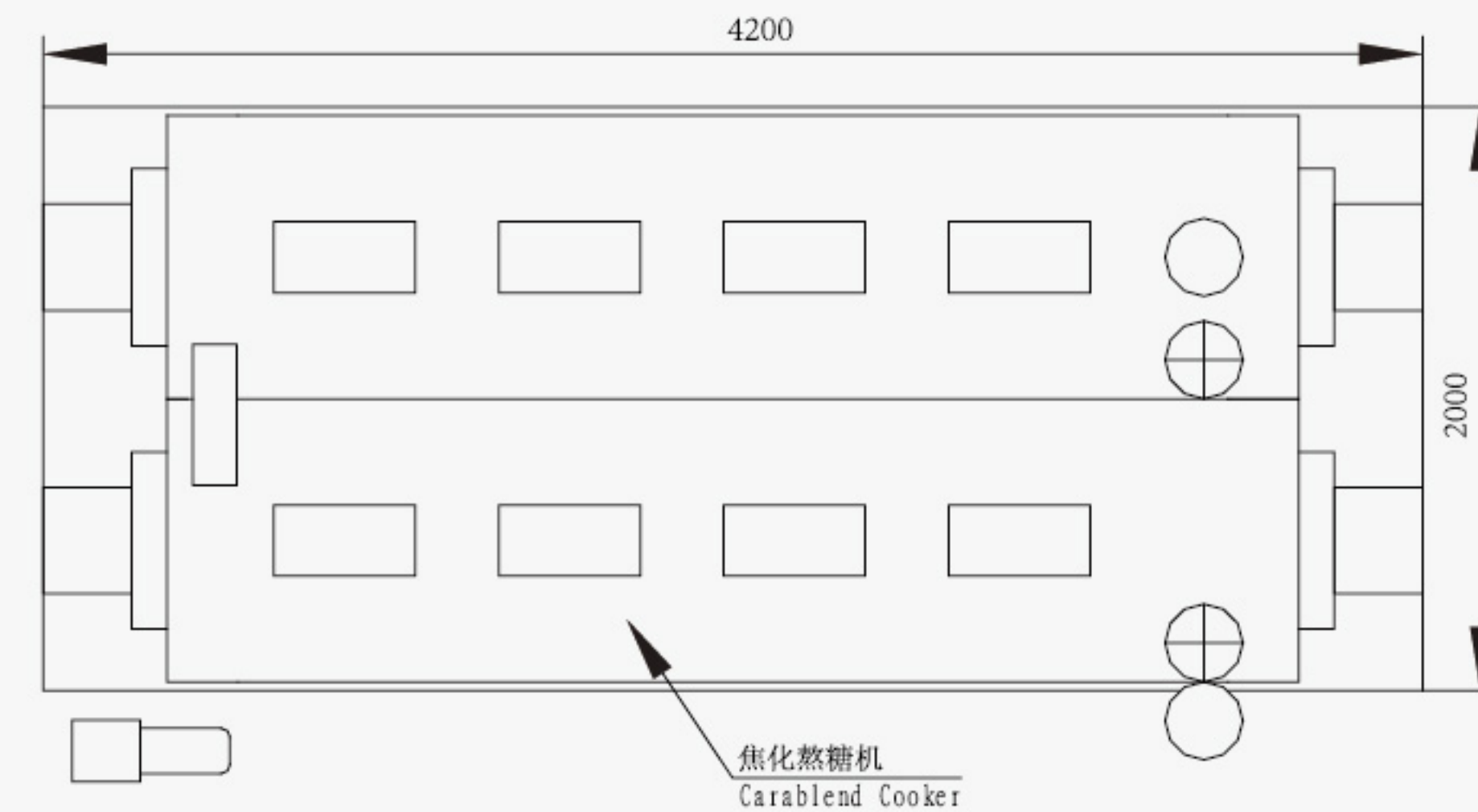



BPCA-300

TOFFEE BATCH COOKER 太妃糖批次熬煮锅



技术规格 SPECIFICATION

生产能力	300-600L
耗电量	10-20kw
压缩空气耗量	0.05-0.1m ³ /min
压缩空气压力	P=0.8MPa
蒸汽耗量	500-1000kg/h
蒸汽压力	P<0.6MPa
用水量	1.5m ³ /min
外形尺寸	2.5m(长)x1.8m(宽)x2.8m(高)
整机重量	800kg

Production capacity	300-600L
Power consumption	10-20kw
Compressed air consumption	0.05-0.1m ³ /min
Air pressure	P=0.8MPa
Steam consumption	500-1000kg/h
Pressure of steam	P<0.6MPa
Water consumption	1.5m ³ /min
Size	2.5m(L)x1.8m(W)x2.8m(H)
Weight of machine	800kg



性能及特点

PURPOSE AND CHARACTERISTIC

BPCA-300——太妃糖熬煮锅外形简单，实用性强，适合中小企业熬煮卡拉蜜尔糖、糖排、太妃糖等，机器控制采用国内知名品牌微处理系统，操作简单易懂，食品接触部分采用食品级不锈钢材料制成。

BPCA-300 toffee batch cooker is simple structure, installed with microprocessor system and easy to operate. The material touched with food is food grade stainless steel. It is practical and suitable for cooking of caramel, bar, toffee and so on.

布局图

LAYOUT

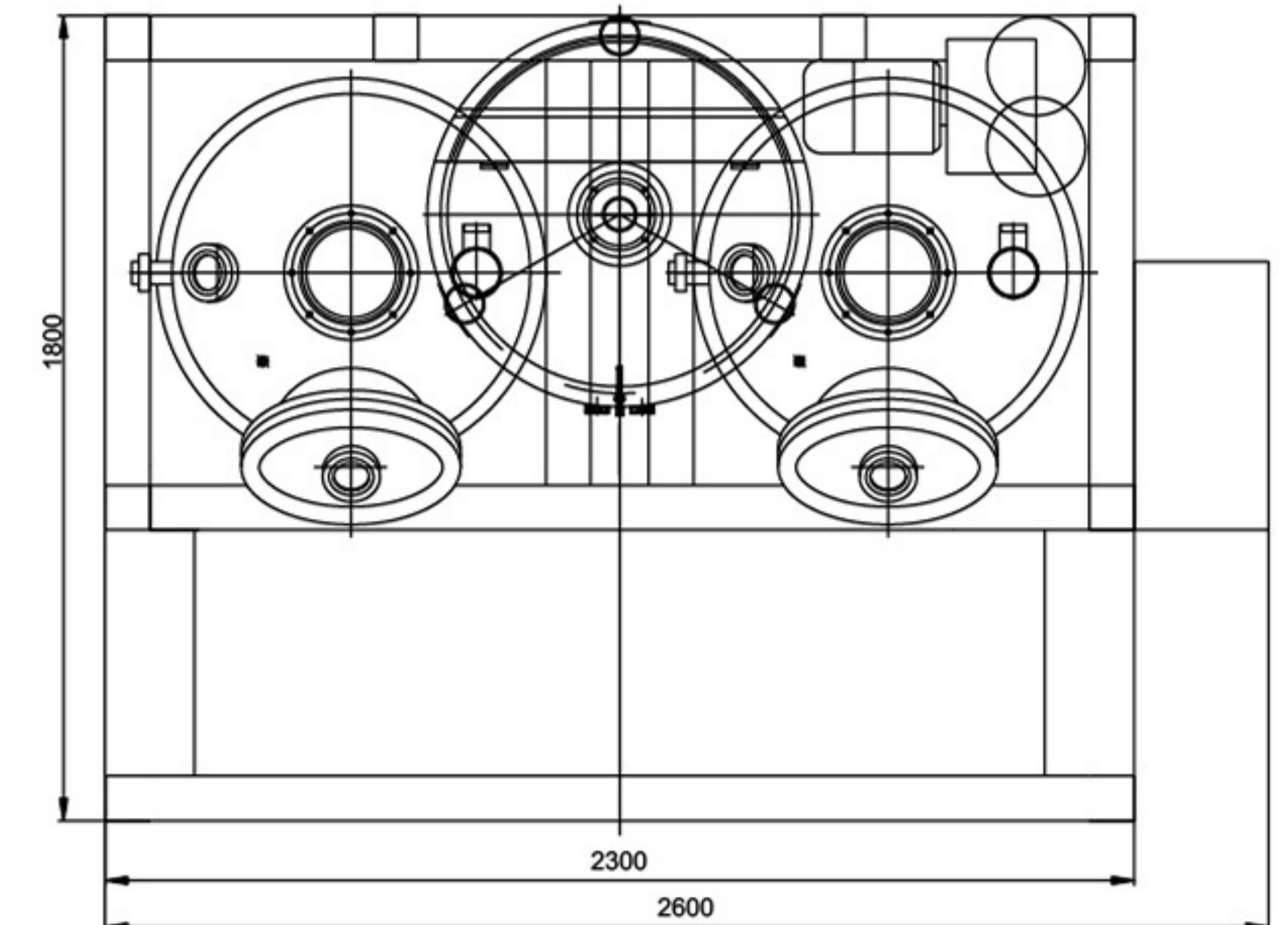



BAFD WEIGHING, MIXING AND FEEDING PLANT

称重，混合喂料系统

适用范围：糖果\医药\化工

APPLICATION: CANDY / PHARMACEUTICAL / INDUSTRIAL

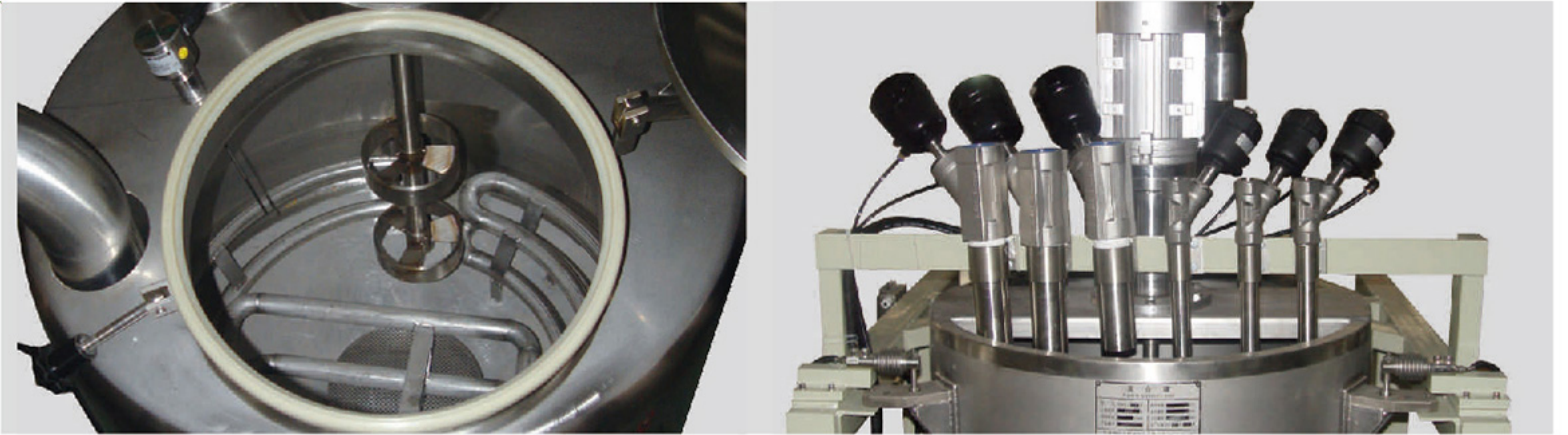

性能及特点 PURPOSE AND CHARACTERISTIC

BAFD 型喂料系统是我公司开发的新型自动化配料设备，适用于食品、医药、化工等行业的配料工序。可按比例配制多种（标准配置7种）流体、可溶性的粉末及颗粒状原料，进行搅拌混合，并按设定温度加热溶解，生产出满足客户要求的高品质配合料。夹层称重罐安装在架子上带有3点称重感应器。暂存溶解罐带盘管系统，使物料在正确的温度进行预溶解混合。

The Warmmix is a weighing and mixing plant, electronically controlled with a micro processor, for the preparation of a pre-heated slurry necessary for the production of gums and jelly. The jacketed weighing vessel is mounted in a frame on a 3 point load cell assembly. The lower holding vessel has a heating coil within it to keep the premix at the correct temperature. The Warmmix is available in a sophisticated version with PLC control system and operating screen or a dedicated batch weighing controller (economy execution). The Warmmix can be used in conjunction with a thermal oil heat exchanger system to guarantee the correct premix temperature with a minimal temperature difference between premix and heating medium.

技术规格 SPECIFICATION

型号 (type)	AFD-11	AFD-12
容量 (capacity: KG/H)	600~750	1200~1500
耗电量 (power: KVA)	14.7	17.7
压缩空气耗量 (compress air:)	400	500
蒸汽耗量 (steam consumption:)	100	200
蒸汽压力 (steam pressure:)	8	8
搅拌罐 (mixing tank:)	280	280
溶解槽 (dissolving tank:)	320	320+320
液压阀 (liquid valve:)	根据客户需求 Specification and quantity according the requirement of customer's	
外形尺寸 (length*width*high:mm)	2100×1400×3060	2100×1800×3060
整机重量 (N.W:)	1000	1300





BLCD CANDY CASTING MACHINE

糖果实验浇注机



技术规格 SPECIFICATION

生产能力	15-30粒/分
浇注量	2-10克
浇注数量	1-2粒/次
糖型	根据客户需求
装机容量	3kw
外形尺寸	1300X1000X1600mm
整机重量	300kg

Capacity	15-30(grains/min)
Weight of pouring	2-10(g)
Number of pouring	1-2(grains/time)
Candy shape	根据客户需求
Total power	3kw
Oversize	1300X1000X1600mm
Total weight	300kg



性能及特点 PURPOSE AND CHARACTERISTIC

BLCD 型全伺服糖果浇注实验机是一种实验室或小批量糖果生产的浇注设备。该机由全伺服电机控制，触摸屏菜单式操作。可用于硬糖，软糖，太妃糖等糖果的浇注，是理想的糖果浇注实验设备。

BLCD full-server candy machine, known as a casting device is used in laboratory or small serial production of candy. As it is controlled by full-server motor and can be operated with menus on the touch screen, it is especially qualified to be applied in casting a variety of candies, including hard candy, soft sweet and toffee.

布局图 LAYOUT

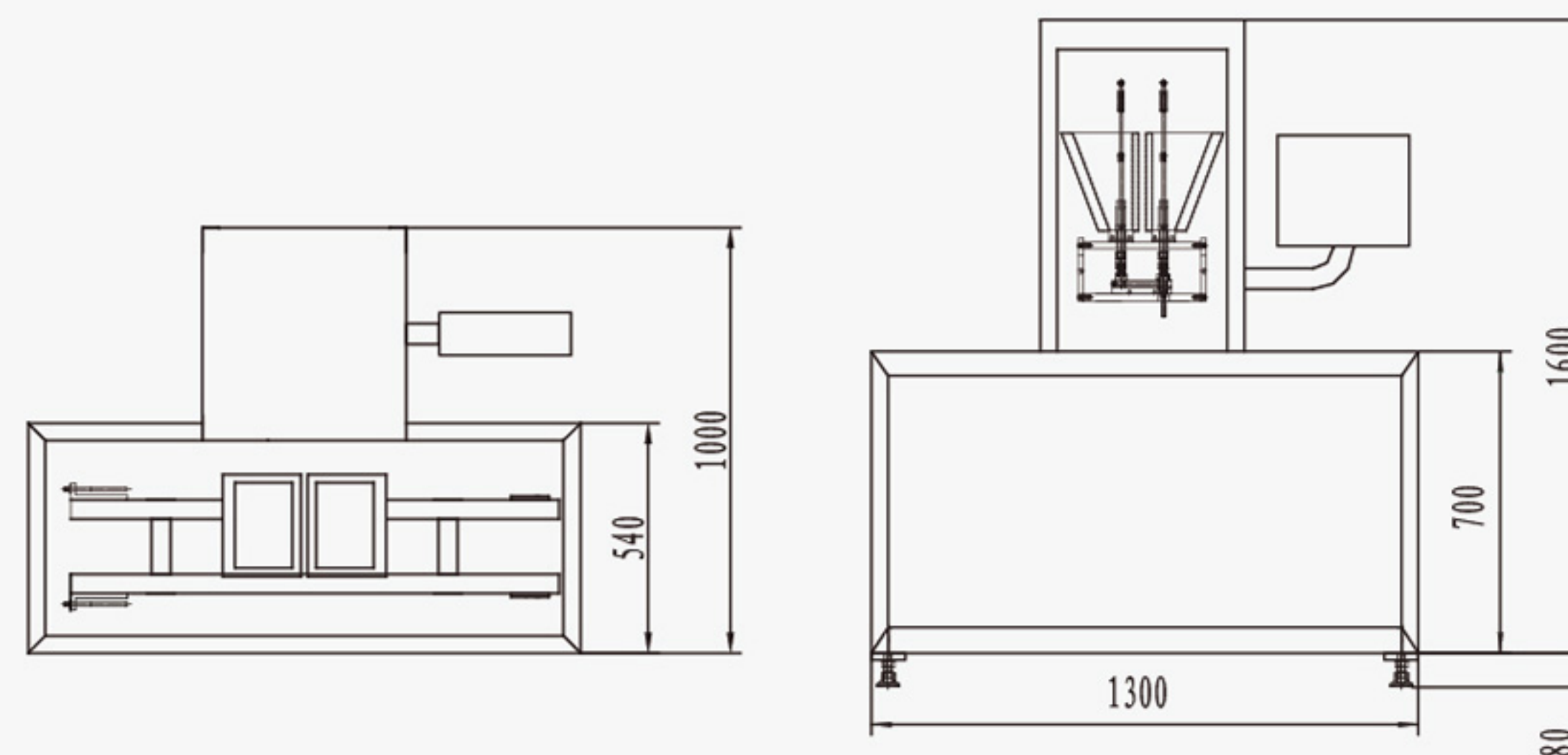



BLB

WHITE PULLING EQUIPMENT

拉白机



技术规格 SPECIFICATION

生产能力	800kg/h
浇注量	-
甩柄数	12个
甩柄转速	5-30转/分
装机容量	7.5kw
外形尺寸	2580x980x1830
整机重量	28000kg

Capacity	800kg/h
Weight of pouring	-
Number of pouring	12
Candy shape	5-30
Total power	7.5kw
Oversize	2580x980x1830
Total weight	28000kg



性能及特点 PURPOSE AND CHARACTERISTIC

BLB拉白机用于将糖浆进行打叠拉白，松软光滑呈白色。该机可以连续进料拉白，连续输出，是生产硬糖，奶糖的辅助设备。可与钢带冷却机，挤出机配套使用。

BLB white pulling equipment is used for making syrup be soft and smooth, it can continuously pulling and output, is the best auxiliary equipment to produce hard candy and soft candy, can be used with steel belt cooling conveyor, extruder and so on

布局图 LAYOUT

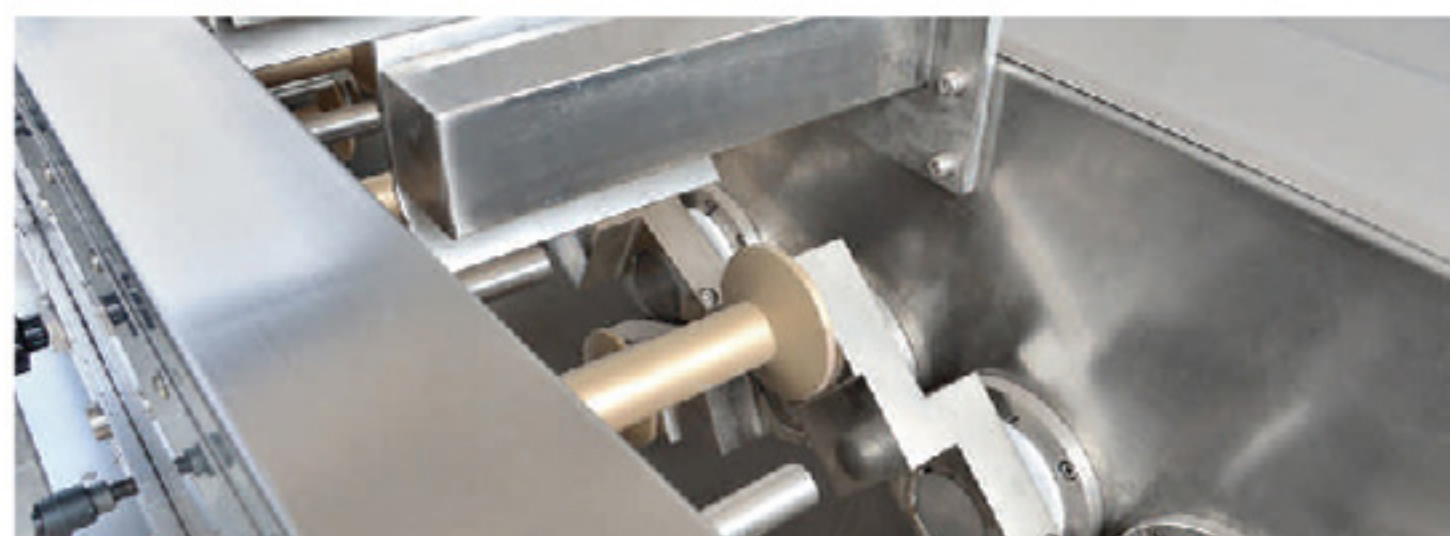
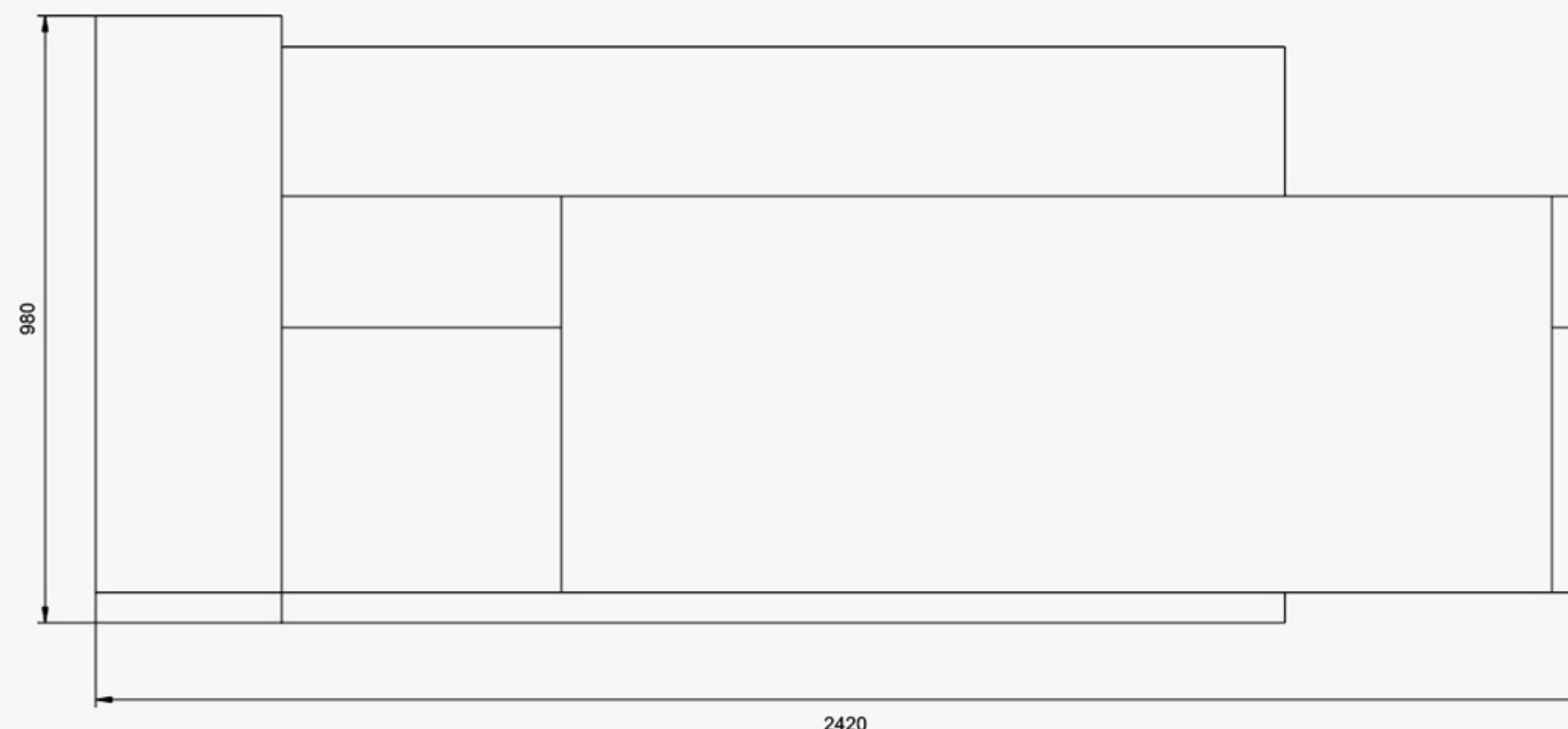



BLBC COOKER FOR CANDY LABORATORY 糖果实验熬煮机



ROTOR PUMP 转子泵

性能及特点 PURPOSE AND CHARACTERISTIC

该熬糖机适用于实验室小批量糖浆的熬制生产，该设备通过对原料进行溶解、加压、真空化、充气、熬煮等不同处理方式满足实验室糖果开发对糖浆的不同需要，熬制的糖浆主要满足硬糖、软糖、淀粉类糖、太妃糖、高温熬制糖果以及无糖糖果的开发。

Laboratory batch cooker is suitable for cooking small capacity syrup in the lab. This machine can dissolve, pressure cook, vacuum, aerate, and cook to satisfy most desired of creating new candy in the lab. The majority production of SAT laboratory batch cooker contain hard candy, starch candy, toffee, high boild sugar and augar free products.

性能及特点 PURPOSE AND CHARACTERISTIC

凸转式双转子泵是采用先进技术研发，精良工艺制造的多用途双向容积泵，产品性能达到国际先进水平，广泛应用于食品、制药等行业。



技术规格 SPECIFICATION

批产量 Capacity	3-6 kg/times
耗电量 Weight of pouring	2kw
蒸汽压力 Number of pouring	0.6 Mpa
外形尺寸 Candy shape	1000X800X1700mm
整机重量 Total weight	200kg

布局图 LAYOUT

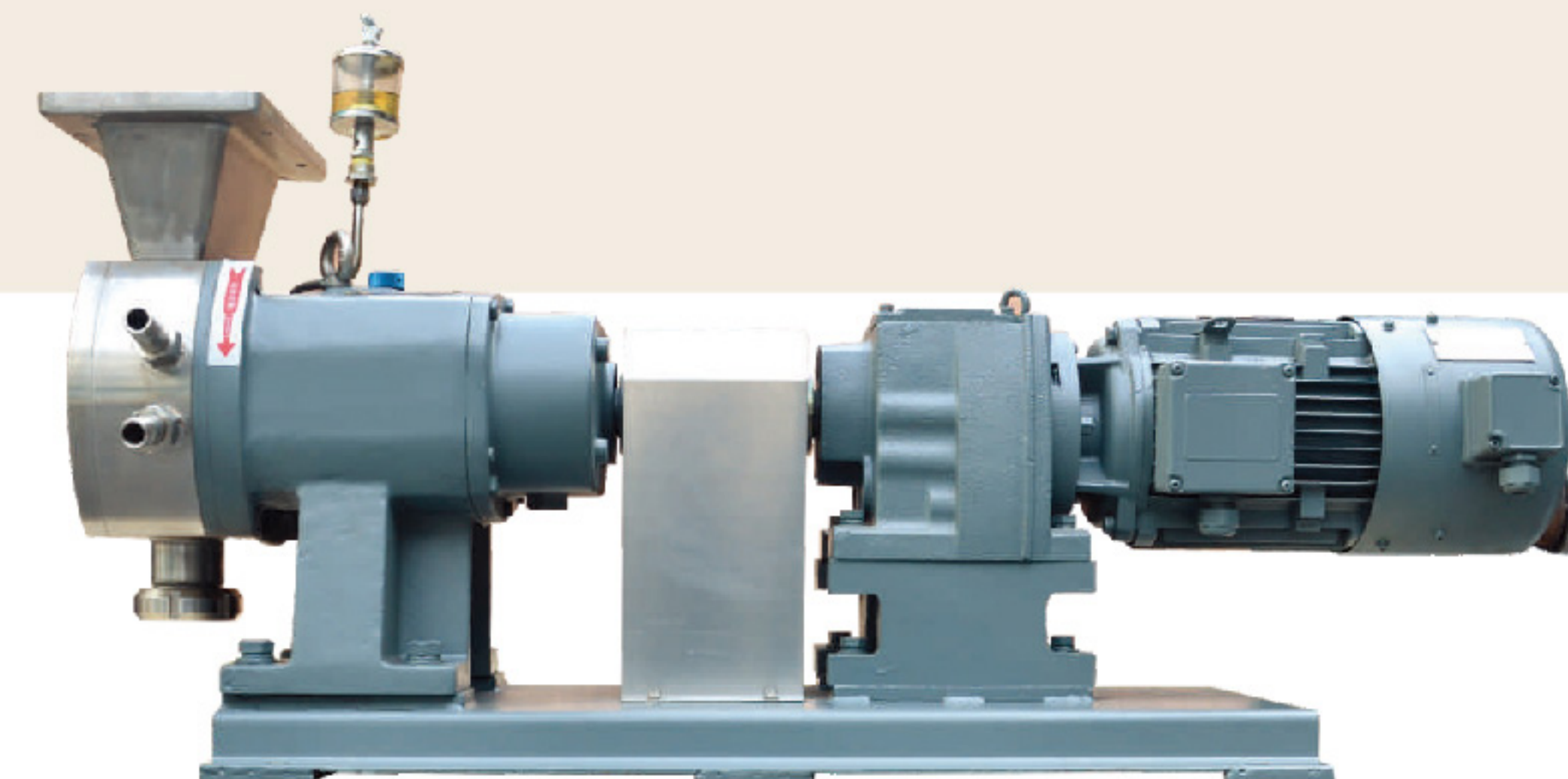
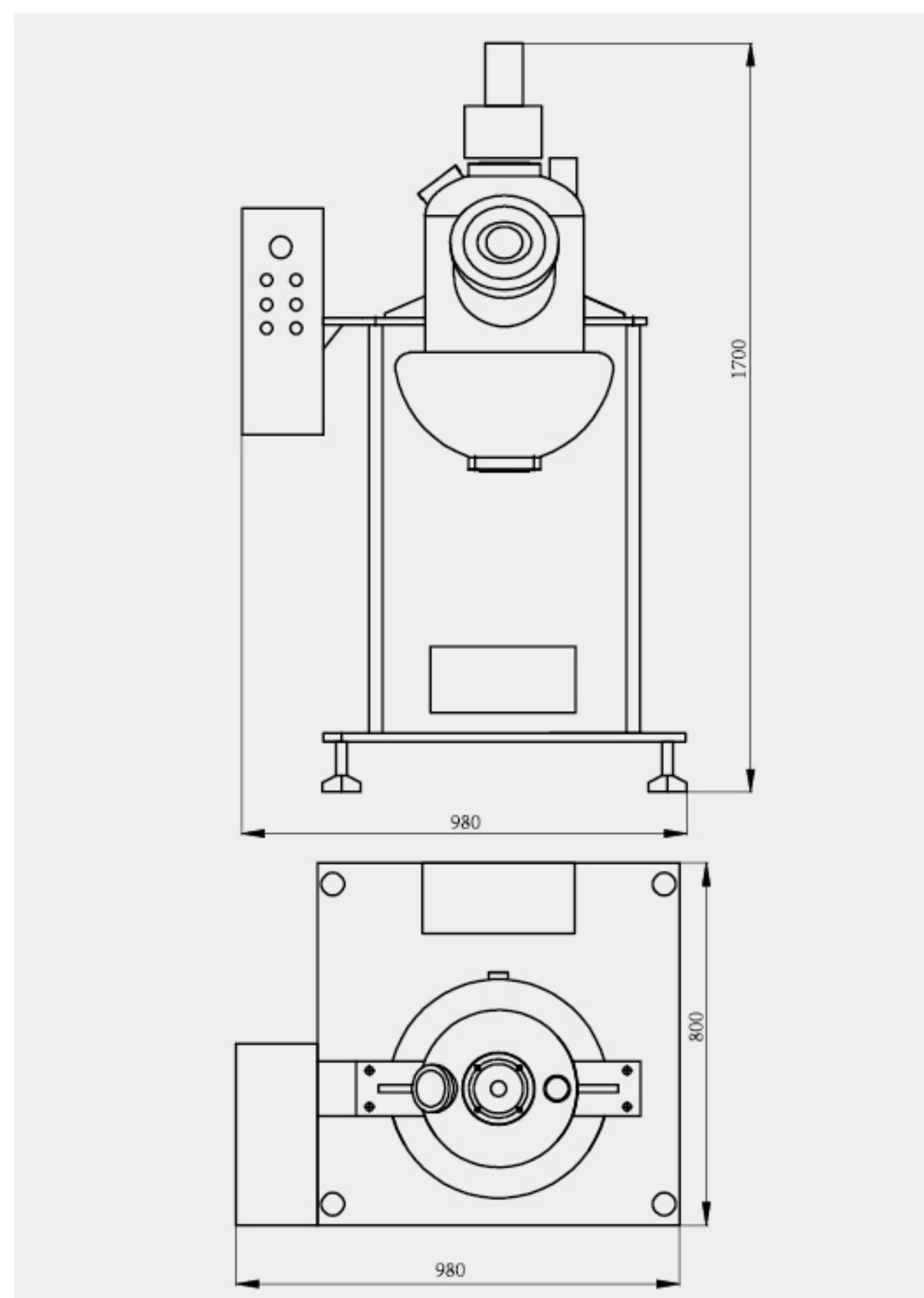

BC50GZB12-10

排量	0.65 L/r
标准流量	10m³/h
功率	1.5-7.5kw
转速	10-500r/min
标准口径	50mm

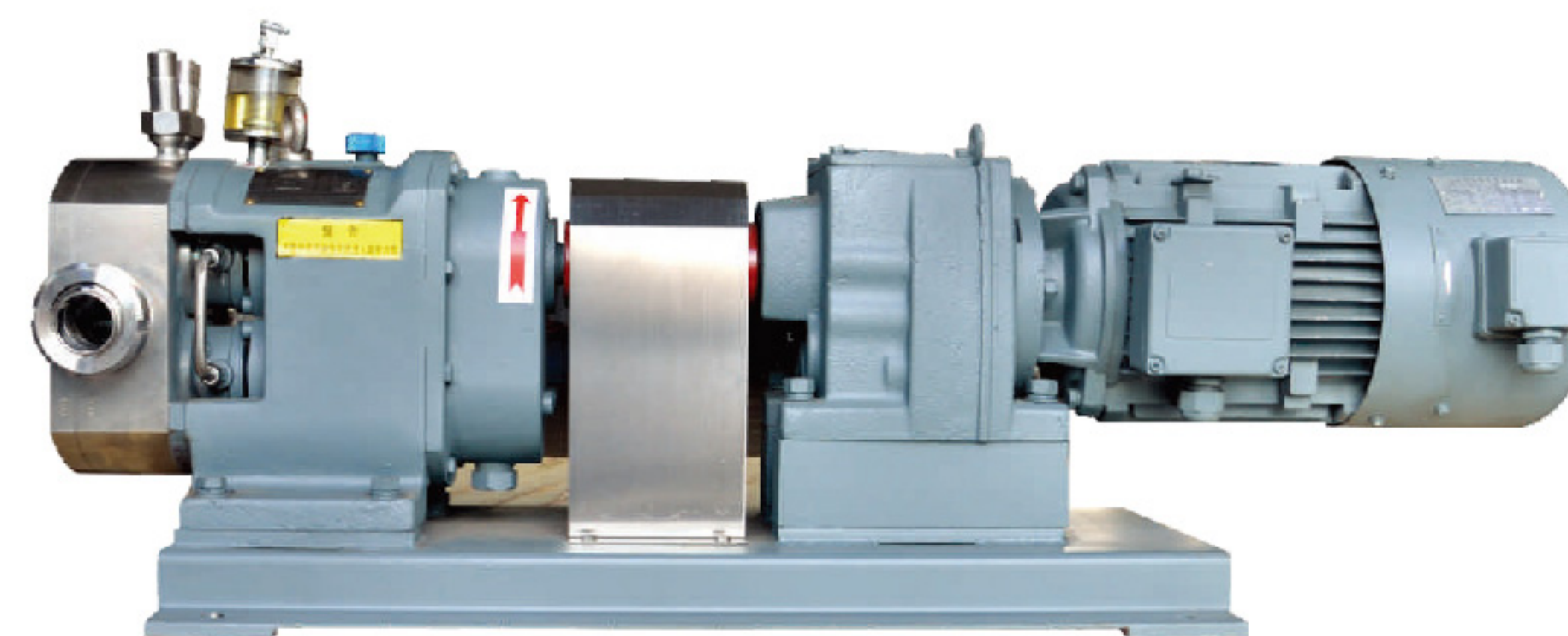

BC40GZB12-5

排量	0.32 L/r
标准流量	5m³/h
功率	0.37-3kw
转速	10-500r/min
标准口径	40mm



CANDY MOULD
糖果模具



CANDY MOULD
糖果模具

BCM-001



话梅	20孔	双排
糖尺寸	糖重	间距
24x15.7mm	4.5g	28.6x38.1mm
26x16mm	6.5g	



BCM-002



杏仁	20孔	双排
糖尺寸	糖重	间距
28x17.5x8.5mm	4g	28.6x38.1mm
30x16x10mm	5.2g	
28x18x11mm	5.5g	



BCM-009



椭圆扣	33孔	三排
糖尺寸	糖重	间距
23.8x17.5x13mm	4.6g	25.4x25.4mm



BCM-010



椰子	20孔	双排
糖尺寸	糖重	间距
24x18x9mm	4.2g	28.6x38.1mm



BCM-003



纽扣	20孔	双排
糖尺寸	糖重	间距
Φ16/18/20/22/23/24/25/26/27x10mm		28.6x38.1mm



BCM-004



椭圆	20孔	双排
糖尺寸	糖重	间距
17.6x26x11mm	4.7g	28.6x38.1mm
15.1x19x7mm	3.3g	
11.5x17.5x10mm	2.5g	
20x12x8mm	2.5g	



BCM-011



阿尔卑斯	20孔	双排
糖尺寸	糖重	间距
Φ19x10.5mm	3.2g	28.6x38.1mm
Φ20x10.5mm	3.5g	
Φ20x12mm	4g	
Φ20x13mm	4.2g	



BCM-012

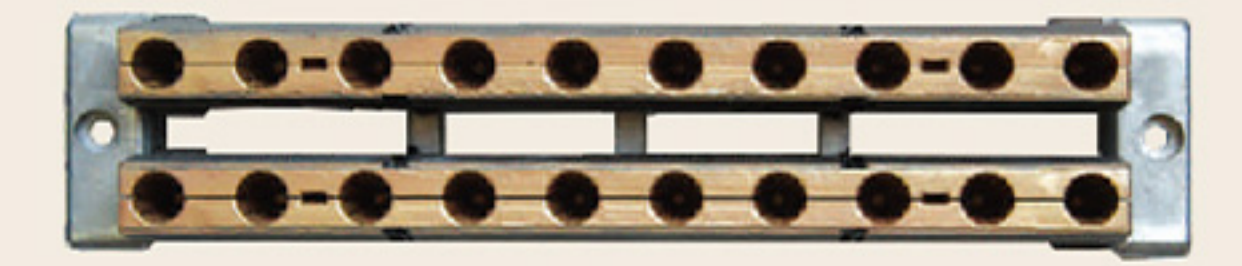

玉米	20孔	双排
糖尺寸	糖重	间距
Φ14.2x32mm	4.6g	28.6x38.1mm



BCM-005



椭圆纽扣	20孔	双排
糖尺寸	糖重	间距
24.5x18x11mm	4.8g	28.6x38.1mm
27x21x12mm	6.5g	
27x20x12mm	6.2g	
26x20x11mm	5.8g	
24x18x11mm	4.8g	
25x18x11mm	5.5g	



BCM-006



椭圆扣	20孔	双排
糖尺寸	糖重	间距
23.8x15x8.5mm	3.8g	28.6x38.1mm
25x16x10.5mm	5.2g	



BCM-013



纽扣	38孔	双排
糖尺寸	糖重	间距
Φ25.5x10mm	5g	27x38.1mm



BCM-014



虫子	10孔	单排
糖尺寸	糖重	间距
70.5x12x9.5mm	8.5g	28.6x38.1mm



BCM-007



小圆	20孔	双排
糖尺寸	糖重	间距
Φ15x10mm	2.4g	28.6x38.1mm
Φ21.5x11.5mm	4.8g	
Φ16.8x15mm	4.5g	
Φ18.8x7.5mm	3g	



BCM-008



草莓&菠萝	20孔	双排
糖尺寸	糖重	间距
25x15x6.5mm	2.5g	28.6x38.1mm



BCM-015

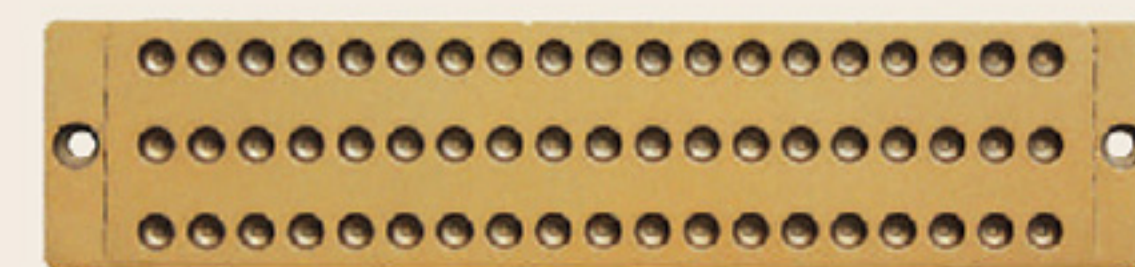

小圆	57孔	三排
糖尺寸	糖重	间距
Φ11x7.5mm	1.3g	14.3x25.4mm



BCM-016



脚丫棒	6孔	单排
糖尺寸	糖重	间距
44x31x8mm	8.5g	45mm





CANDY MOULD
糖果模具



CANDY MOULD
糖果模具

BCM-017



话梅棒	6孔	双排
糖尺寸	糖重	间距
Φ32x20.7mm	9.5g	98x38.1mm



BCM-018



球棒	20孔	双排
糖尺寸	糖重	间距
任意外径	任意克重	30x68mm



BCM-025



圆	10孔	单排
糖尺寸	糖重	间距
Φ27x13.5mm	14g	28.6mm

BCM-026



圆	10孔	单排
糖尺寸	糖重	间距
Φ26x11mm	5.5g	28.6mm

BCM-019



话梅棒	8孔	单排
糖尺寸	糖重	间距
Φ28x18.5mm	8.5g	35mm



BCM-020



玉米	10孔	单排
糖尺寸	糖重	间距
Φ19.2x42mm	14g	28.6mm



BCM-027



圆	10孔	单排
糖尺寸	糖重	间距
Φ27.5x14.5mm	6.5g	28.6mm

BCM-028



腰圆	6孔	单排
糖尺寸	糖重	间距
37x21.6x18.3mm	9.2g	42mm

BCM-021



草莓	10孔	单排
糖尺寸	糖重	间距
17.6x21mm	4.2g	28.6mm
15.5x18.5mm	3.5g	
14.5x18mm	3.2g	



BCM-022



面包型	9孔	单排
糖尺寸	糖重	间距
31x18.5mm	5.5g	26mm



BCM-029



圆	20孔	双排
糖尺寸	糖重	间距
Φ22.5x12.5mm	4.5g	28.6x38.1mm
Φ20x12mm	3.8g	
Φ22x12mm	4g	

BCM-030



圆	20孔	双排
糖尺寸	糖重	间距
25.4x19x11.6mm	4.8g	28.6x38mm

BCM-023

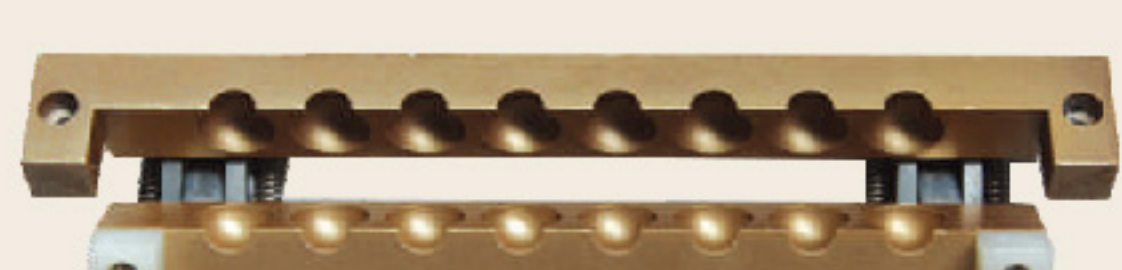

圆球棒	8孔	单排
糖尺寸	糖重	间距
Φ20mm	6.3g	28.6mm
Φ21mm	7g	
Φ23mm	9g	
Φ24mm	10.5g	
Φ25mm	12g	



BCM-024



猴头棒	8孔	双排
糖尺寸	糖重	间距
39x34x9.3mm	9g	98x38.1mm



BCM-031



圆	14孔	双排
糖尺寸	糖重	间距
Φ30x17.5mm	8g	35x36mm

BCM-032



长方形	64孔	四排
糖尺寸	糖重	间距
39.5x19.5x16mm	5.8g	30x42mm